

q -DERIVATIVE GRAMMAR

GUO-NIU HAN, KATHY Q. JI, AND HUAN XIONG

ABSTRACT. The concept of *context-free grammar* in Combinatorics was first introduced by Chen in 1993. In 1996, Dumont significantly extended the theory of context-free grammars to a variety of other combinatorial models. Substantial progress in this direction has been achieved over the last decade. In this paper, we introduce a q -analogue of context-free grammars, which we call the *q -derivative grammar*. We establish the basic framework of q -grammars and develop the q -grammar calculus for computing q -exponential generating functions associated with q -grammars. Concrete q -grammars are constructed to study q -Eulerian, q -Roselle and q -André polynomials, including their generating functions and recurrences. This work extends the grammatical method to the q -setting and opens up new research directions.

1. INTRODUCTION

The concept of *context-free grammar* in Combinatorics was first introduced by Chen [5] in 1993. Within this framework, Chen derived elegant proofs of Faà di Bruno's formula, along with several identities involving Bell polynomials, Stirling numbers, and symmetric functions. In particular, the Lagrange inversion formula receives a concise grammatical interpretation, from which Cayley's formula for labeled trees follows in a natural way. Subsequently, in 1996, Dumont significantly extended the theory of context-free grammars to a variety of other combinatorial models [19]. Substantial progress in this direction has been achieved over the past decade. An overview of these developments is presented in Appendix I.

The objective of this paper is to develop a q -analogue of context-free grammar, which we refer to as the *q -derivative grammar* (or q -grammar for short). To the best of our knowledge, no such q -analogue has been constructed in the past three decades, apart from a study about the multivariable tangent and secant q -derivative polynomials due to Foata and Han [24].

Date: 2026/04/26.

2020 Mathematics Subject Classification. 05A05, 05A15, 05A19, 05A30.

Key words and phrases. q -derivative grammar, context-free grammar, q -binomial inversion, permutation statistics, André permutations.

Constructing a q -analogue of combinatorial context-free grammar poses substantial challenges. Beyond introducing the additional parameter q consistently throughout all computations, this generalization fundamentally converts elementary commutative calculations into highly nontrivial non-commutative operations. We address this non-commutative obstacle in Section 2 using the q -product formula for the q -derivative [24].

Having reviewed the non-commutative computation in Section 2, we proceed in Section 3 to rigorously define the formal q -derivative grammar. Nevertheless, we first confront a foundational notational choice. As claimed by Chen [5], combinatorial context-free grammars borrow terminology from formal language theory, where standard definitions are universally tuple-based, see [15, 37, 56]. In contrast, combinatorial applications traditionally adopt simplified, streamlined definitions. For the rigorous formulation of our q -derivative grammar, we revert to the tuple-based framework, which is better suited to our algebraic and combinatorial requirements. We next address the natural combinatorial questions motivated by q -derivative grammars. For a fixed q -grammar, key problems include seeking concrete combinatorial interpretations, enumerating the number of terms, and deriving associated generating functions. We systematically investigate these problems and supply illustrative examples in Section 3.

In Section 4, we develop a unified computational tool, called q -grammar calculus, to compute the q -exponential generating functions associated with the corresponding q -grammars. As illustrations of this method, we provide grammatical derivations of the q -binomial inversion formula and the q -Hoffman formula. We then construct specialized q -grammars to produce q -analogs of the Eulerian polynomials, the Roselle polynomials, and two q -analogs of the André polynomials in Sections 5 and 6, respectively. Based on these q -grammars, we obtain grammatical derivations of the q -exponential generating functions for the q -Eulerian polynomials (due to Stanley) and the cycle q -Roselle polynomials. Recurrence relations for the two q -André polynomials are also derived using the q -grammar calculus developed in Section 4.

Lastly, we believe that most of the topics discussed in Appendix I within the framework of context-free grammars can be extended to the q -analogue by employing q -derivative grammars. Consequently, this line of research offers many promising directions for further investigation.

2. q -DERIVATIVE

Let \mathbb{K} be a commutative ring with unity and characteristic zero. For $f(u) \in \mathbb{K}[[u]]$, the q -derivative operator [32, p. 22] used in this paper is defined as

$$D_q f(u) := \frac{f(u) - f(qu)}{u}, \quad (2.1)$$

which differs from the conventional form:

$$\frac{f(qu) - f(u)}{(q-1)u}.$$

For $n \geq 1$, we recursively define $D_q^n(u) = D(D_q^{n-1}(u))$.

For $f(u), g(u) \in \mathbb{K}[[u]]$, we have the product rule

$$D_q(f(u)g(u)) = D_q(f(u))g(qu) + f(u)D_q(g(u)),$$

In general, for $f_i(u) \in \mathbb{K}[[u]]$ where $1 \leq i \leq n$, we have

Proposition 2.1. [24, (4.2)] *We have*

$$\begin{aligned} D_q \left(\prod_{1 \leq i \leq n} f_i(u) \right) \\ = \sum_{1 \leq i \leq n} f_1(u) \cdots f_{i-1}(u) \cdot D_q(f_i(u)) \cdot f_{i+1}(qu) \cdots f_n(qu). \end{aligned} \quad (2.2)$$

A straightforward computation yields the following useful identity:

$$D_q(f(q^m u)) = q^m \cdot D_q(f(x)) \Big|_{x=q^m u}. \quad (2.3)$$

The q -analogues of the exponential function e^x , first introduced by Euler [21], are given by (see [32, p. 9]):

$$e_q(u) = \sum_{n \geq 0} \frac{u^n}{(q; q)_n} = \frac{1}{(u; q)_\infty}, \quad (2.4)$$

$$E_q(u) = \sum_{n \geq 0} q^{\binom{n}{2}} \frac{u^n}{(q; q)_n} = (-u; q)_\infty, \quad (2.5)$$

where the q -shifted factorial is defined by

$$(u; q)_n := \begin{cases} 1, & \text{if } n = 0, \\ (1-u)(1-uq) \cdots (1-uq^{n-1}), & \text{if } n \geq 1, \end{cases}$$

$$(u; q)_\infty := \lim_{n \rightarrow \infty} (u; q)_n = \prod_{n \geq 0} (1-uq^n).$$

They both serve to define the q -trigonometric functions [38]:

$$\begin{aligned} \sin_q(u) &:= \frac{e_q(iu) - e_q(-iu)}{2i}, & \cos_q(u) &:= \frac{e_q(iu) + e_q(-iu)}{2}, \\ \text{Sin}_q(u) &:= \frac{E_q(iu) - E_q(-iu)}{2i}, & \text{Cos}_q(u) &:= \frac{E_q(iu) + E_q(-iu)}{2}, \\ \sec_q(u) &:= \frac{1}{\cos_q(u)}, & \text{Sec}_q(u) &:= \frac{1}{\text{Cos}_q(u)}, & \tan_q(u) &:= \frac{\sin_q(u)}{\cos_q(u)}. \end{aligned}$$

The following q -derivative formulas for the q -trigonometric functions are given by Foata and Han [24]:

Proposition 2.2 ([24]). *We have*

$$D_q(\tan_q(u)) = 1 + \tan_q(u) \tan_q(qu),$$

$$D_q(\sec_q(u)) = \sec_q(qu) \tan_q(u),$$

$$D_q(\text{Sec}_q(u)) = \text{Sec}_q(u) \tan_q(qu).$$

In the q -product formula (2.2), although the left-hand side of the q -product formula is symmetric in the functions f_i , this symmetry is not explicit in the right-hand side, which depends on the ordering of the functions. We illustrate this subtlety with an example. From the identity

$$D(\tan_q(u)) = 1 + \tan_q(u) \tan_q(qu) = 1 + \tan_q(qu) \tan_q(u),$$

there are several ways to compute $D^2 \tan_q(u)$ via the q -product formula. One such method is the following:

$$\begin{aligned} D_q^2 \tan_q(u) &= D_q(1 + \tan_q(u) \tan_q(qu)) \\ &= \tan_q(u) D_q(\tan_q(qu)) + D_q(\tan_q(u)) \tan_q(q^2u) \\ &= \tan_q(u) q(1 + \tan_q(qu) \tan_q(q^2u)) \\ &\quad + (1 + \tan_q(u) \tan_q(qu)) \tan_q(q^2u) \\ &= q \tan_q(u) + \tan_q(q^2u) + (1 + q) \tan_q(u) \tan_q(qu) \tan_q(q^2u). \end{aligned}$$

To simplify notation, we introduce the shorthand

$$x_j := \tan_q(q^j u).$$

Using this substitution, the first identity in Proposition 2.2 combined with (2.3) becomes

$$D_q(x_j) = q^j (1 + x_j x_{j+1}). \quad (2.6)$$

The first computation can then be rewritten compactly as

$$\begin{aligned} D_q^2(x_0) &= D_q(1 + x_0 x_1) \\ &= x_0 D_q(x_1) + D_q(x_0) x_2 \\ &= x_0 q(1 + x_1 x_2) + (1 + x_0 x_1) x_2 \\ &= qx_0 + x_2 + (1 + q)x_0 x_1 x_2. \end{aligned}$$

A second natural derivation gives

$$\begin{aligned} D_q^2(x_0) &= D_q(1 + x_1 x_0) \\ &= x_1 D_q(x_0) + D_q(x_1) x_1 \\ &= x_1 (1 + x_0 x_1) + q(1 + x_1 x_2) x_1 \\ &= (1 + q)x_1 + x_0 x_1^2 + qx_1^2 x_2. \end{aligned}$$

Notably, both derivations depend only on the identity (2.6) and the q -product formula, without using any special properties of the function \tan_q

itself. This observation motivates the definition of our q -derivative grammar, which will be presented in Section 3.

3. FOUNDATIONS OF q -DERIVATIVE GRAMMAR

As noted by Chen [5], the terminology of context-free grammars used in Combinatorics is inspired by that of context-free grammars in formal language theory. In formal language theory, one consistently uses *tuple-based definitions*, see [15, 37, 56]. In contrast, in Combinatorics, one usually prefers a much simpler way of stating definitions.

For our definition of a q -derivative grammar, we return to the tuple-based framework, which is more convenient for our purposes. We therefore begin by introducing some fundamental concepts that will serve as preparatory material for our tuple-based definition of the q -derivative grammar.

3.1. Free group and group algebra. Free groups and group algebras are two fundamental concepts in algebra, playing important roles in group theory and representation theory. The following definitions are well-known and can be found in [41, 51].

Definition 3.1 (Free Group). Let S be a set. Consider the alphabet $S \cup S^{-1}$, where $S^{-1} = \{s^{-1} \mid s \in S\}$ is a set of formal inverses. A *word* is a finite sequence of elements from $S \cup S^{-1}$. A word is called *reduced* if it contains no adjacent pair of the form ss^{-1} or $s^{-1}s$ for any $s \in S$. The *free group* on S , denoted $F(S)$, consists of all reduced words. The group operation is concatenation followed by reduction (removing adjacent inverse pairs). The empty word is the identity element, and the inverse of a word $x_1x_2 \cdots x_n$ is $x_n^{-1} \cdots x_2^{-1}x_1^{-1}$.

Definition 3.2. Let \mathbb{K} be a commutative ring with unity and characteristic zero and G be a group. The *group algebra* $\mathbb{K}[G]$ is the set of all formal finite sums

$$\sum_{g \in G} \alpha_g g, \quad \alpha_g \in \mathbb{K},$$

where only finitely many coefficients α_g are non-zero. Addition is defined component-wise:

$$\sum_g \alpha_g g + \sum_g \beta_g g = \sum_g (\alpha_g + \beta_g)g.$$

Multiplication is defined by extending the group multiplication linearly:

$$\left(\sum_{g \in G} \alpha_g g \right) \left(\sum_{h \in G} \beta_h h \right) = \sum_{g, h \in G} (\alpha_g \beta_h)(gh).$$

This makes $\mathbb{K}[G]$ an associative \mathbb{K} -algebra with identity $1_{\mathbb{K}} \cdot e_G$, where e_G is the identity element of G .

3.2. Basic algebraic structures. Let q be an indeterminate, let \mathbb{K} be a commutative ring with unity and characteristic zero, and let S be a (finite or infinite) set of symbols, called *master variables*. To each master variable $s \in S$ we associate an infinite family of indexed non-commutative variables

$$s_0, s_1, s_2, \dots$$

The total set of variables is denoted by $\mathbb{S} := S^{\mathbb{N}} := \{s_i : s \in S, i \in \mathbb{N}\}$, where $\mathbb{N} = \{0, 1, 2, \dots\}$.

The fundamental algebraic object in the formal q -grammar framework is the *group algebra* $\mathbb{K}[q][F(\mathbb{S})]$ on $F(\mathbb{S})$, denoted by \mathbb{E} . Therefore, an element of \mathbb{E} , called an *expression*, is a (finite) $\mathbb{K}[q]$ -linear combination of words in the variables from the free group $F(\mathbb{S})$, that is,

$$E = \sum_{w \in F(\mathbb{S})} a_w w,$$

where each coefficient a_w lies in $\mathbb{K}[q]$. The sum is finite in the sense that $a_w = 0$ for all but finitely many words $w \in F(\mathbb{S})$. The scalar a_w is referred to as the *coefficient* of the word w in the expression E .

3.3. Rules. A *rule* $R: \mathbb{S} \cup \mathbb{S}^{-1} \rightarrow \mathbb{E}$ is a map that assigns to each variable in $\mathbb{S} \cup \mathbb{S}^{-1}$ an expression in \mathbb{E} . More precisely, the rule is first defined on the set of variables in \mathbb{S} , where it is typically written as

$$\{s_0 \mapsto R(s_0), s_1 \mapsto R(s_1), \dots\}.$$

The definition is then extended to the set of formal inverses s_i^{-1} by setting, for each $s_i \in \mathbb{S}$,

$$R(s_i^{-1}) := -s_i^{-1} R(s_i) s_{i+1}^{-1}.$$

For instance, as will be discussed later, the assignment

$$R = \{x_j \mapsto q^j(1 + x_j x_{j+1})\}$$

constitutes a rule. The purpose of a rule is to transform a given expression into a new expression.

3.4. Orders. An *order* is a map that rewrites a word in $F(\mathbb{S})$ by permuting the non-commutative variables in \mathbb{S} . This order is extended to arbitrary expressions in $\mathbb{E} := \mathbb{K}[q][F(\mathbb{S})]$ by linearity. In this paper, the following four orders are frequently employed.

Definition 3.3. For a set of master variables $S = \{x, y, \dots\}$, we define the following special orders based on priority rules.

- **KSO (Keep Sequence Order):** This is the identity map, which leaves the word unchanged.

- **LPO (Letter-Priority Order)**: This rewrites the word by prioritizing all x variables before all y variables, preserving their internal index order, i.e., reordering variables associated with the order

$$x_0, x_1, x_2, \dots, \quad y_0, y_1, y_2, \dots$$

- **AIO (Ascending Interleaving Order)**: This rewrites the word by interleaving x and y variables in ascending index order, i.e., reordering variables associated with the order

$$x_0, y_0, x_1, y_1, x_2, y_2, \dots$$

- **DIO (Descending Interleaving Order)**: This rewrites the word by interleaving x and y variables in descending index order, i.e., reordering variables associated with the order

$$\dots, x_2, y_2, x_1, y_1, x_0, y_0.$$

For example, take $S = \{x, y\}$ and let $E = x_2 y_2^{-1} x_1 x_3^2 y_3 + (1+q) y_1^2 x_1^{-1} x_2 \in \mathbb{E}$. Then

$$\mathbf{KSO}(E) = x_2 y_2^{-1} x_1 x_3^2 y_3 + (1+q) y_1^2 x_1^{-1} x_2 = E,$$

$$\mathbf{LPO}(E) = x_1 x_2 x_3^2 y_2^{-1} y_3 + (1+q) x_1^{-1} x_2 y_1^2,$$

$$\mathbf{AIO}(E) = x_1 x_2 y_2^{-1} x_3^2 y_3 + (1+q) x_1^{-1} y_1^2 x_2,$$

$$\mathbf{DIO}(E) = x_3^2 y_3 x_2 y_2^{-1} x_1 + (1+q) x_2 x_1^{-1} y_1^2.$$

3.5. Definition of q -derivative grammar. We now introduce the main definition of this work.

Definition 3.4. A formal q -derivative grammar (or q -grammar for short) G over a commutative ring \mathbb{K} with unity and characteristic zero is a triple

$$G = (S, R, \rho),$$

where

- S denotes a finite or infinite set of *master variables*,
- R is a rule,
- ρ is an order.

For instance, the following triples define two formal q -derivative grammars:

$$G_{\text{tan}} = (S = \{x\}, R = \{x_j \rightarrow q^j(1 + x_j x_{j+1})\}, \rho = \mathbf{DIO}), \quad (3.1)$$

and

$$G_{\text{tan}'} = (S = \{x\}, R = \{x_j \rightarrow q^j(1 + x_j x_{j+1})\}, \rho = \mathbf{LPO}). \quad (3.2)$$

3.6. q -derivative operator D . The goal of our framework for q -derivative grammars is to perform certain computations. We begin by defining the up-arrow operator.

Definition 3.5. The *up-arrow operator* $\uparrow: \mathbb{E} \rightarrow \mathbb{E}$ is a linear operator that acts on words over $F(\mathbb{S})$ by increasing the index of each variable in $\mathbb{S} \cup \mathbb{S}^{-1}$ by 1. In general, for a positive integer k , \uparrow^k denotes the operator that increases the index of each variable in $\mathbb{S} \cup \mathbb{S}^{-1}$ by k .

For example, if $S = \{x, y\}$, then

$$\uparrow(y_2^{-1}x_0x_0y_1) = y_3^{-1}x_1x_1y_2 \quad \text{and} \quad \uparrow^3(y_2^{-1}x_0x_0y_1) = y_5^{-1}x_3x_3y_4.$$

Definition 3.6. Let $G = (S, R, \rho)$ be a q -derivative grammar. The *q -derivative operator* $D: \mathbb{E} \rightarrow \mathbb{E}$ associated with G is the linear operator defined by

$$D(w_1w_2 \cdots w_n) := \sum_{j=1}^n \rho(w_1w_2 \cdots w_{j-1}R(w_j) \uparrow(w_{j+1} \cdots w_n)),$$

for each word $w_1w_2 \cdots w_n$, where each $w_j \in \mathbb{S} \cup \mathbb{S}^{-1}$.

Note that the expression $\uparrow w_{j+1}$ is not to be interpreted as w_{j+2} . For instance, if $w_{j+1} = s_3$, then $\uparrow w_{j+1} = \uparrow s_3 = s_4$.

Note that q -derivative operator is well-defined, since

$$D(x_i x_i^{-1}) = \rho(R(x_i) \cdot x_{i+1}^{-1} - x_i \cdot x_i^{-1} R(x_i) x_{i+1}^{-1}) = 0$$

and

$$D(x_i^{-1} x_i) = \rho(-x_i^{-1} R(x_i) x_{i+1}^{-1} \cdot x_{i+1} + x_i^{-1} \cdot R(x_i)) = 0.$$

Definition 3.7. Let $G = (S, R, \rho)$ be a q -grammar. The high order q -derivative operator D^k associated with G is defined by $D^0(f) = f$, and for $k \geq 1$, $D^k(f) = D(D^{k-1}(f))$ for $f \in \mathbb{E}$.

For example, take the grammar G_{tan} defined in (3.1), we have

$$\begin{aligned} D(x_0) &= \mathbf{DIO}(1 + x_0x_1) = 1 + x_1x_0, \\ D^2(x_0) &= \mathbf{DIO}(R(x_1)x_1 + x_1R(x_0)) \\ &= \mathbf{DIO}(q(1 + x_1x_2)x_1 + x_1(1 + x_0x_1)) \\ &= (1 + q)x_1 + x_1x_1x_0 + qx_2x_1x_1. \end{aligned} \tag{3.3}$$

For a second example, we take the grammar $G_{\text{tan}'}$ defined in (3.2). We have

$$\begin{aligned} D(x_0) &= \mathbf{LPO}(1 + x_0x_1) = 1 + x_0x_1, \\ D^2(x_0) &= \mathbf{LPO}(R(x_0)x_2 + x_0R(x_1)) \\ &= \mathbf{LPO}((1 + x_0x_1)x_2 + x_0q(1 + x_1x_2)) \\ &= qx_0 + x_2 + (1 + q)x_0x_1x_2. \end{aligned} \tag{3.4}$$

Let G be a q -grammar and let f be an expression in \mathbb{E} . The high order q -derivative associated with G can be written in the following form:

$$D^k(f) = \sum_{w \in F(\mathbb{S})} a_w w.$$

In general, the computation of higher-order q -derivatives associated with the q -grammars is lengthy and technically involved. To facilitate these computations, we provide a SageMath package, `qgrammar.sage`, which is accessible on the first author's personal webpage at

<https://irma.math.unistra.fr/~guoniu/qgrammar.html>.

On this webpage, we also compile the initial higher-order q -derivatives associated with the q -grammars investigated in this paper.

3.7. Evaluation on q -grammars. Let $G = (S, R, \rho)$ be a q -grammar, and let \mathbb{V} be a commutative ring. Recall that \mathbb{S} is the set of all non-commutative variables and \mathbb{E} is the free $\mathbb{K}[q]$ -algebra generated by \mathbb{S} . An *evaluation* ϕ on a q -grammar is a map $\phi: \mathbb{S} \rightarrow \mathbb{V}$ that sends each non-commutative variable to a commutative element of \mathbb{V} . Such an evaluation is typically expressed in the form:

$$\{x_0 \mapsto \phi(x_0), x_1 \mapsto \phi(x_1), \dots\}.$$

The evaluation map ϕ can be uniquely extended to a morphism $\phi: \mathbb{E} \rightarrow \mathbb{V}$ by preserving linearity, multiplicativity and invertibility (i.e., $\phi(x_0^{-1}) := \phi(x_0)^{-1}$).

For instance, take $\mathbb{V} = \mathbb{Z}[[u, q]]$, the assignment

$$\phi = \{x_j \mapsto \tan_q(q^j u)\}$$

constitutes an evaluation. Applying this evaluation to the expression (3.3) for the the grammar G_{\tan} , we get

$$\phi(D^2(x_0)) = q \tan_q(u) + \tan_q(q^2 u) + \tan_q(u) \tan_q(qu) \tan_q(q^2 u) \in \mathbb{Z}[[u, q]].$$

3.8. Research problems on q -grammars. Let $G = (S, R, \rho)$ be a q -grammar and let f be an expression in \mathbb{E} . The high order q -derivative associated with G on f can be written in the following form:

$$D^k(f) = \sum_{w \in F(\mathbb{S})} a_w w. \tag{3.5}$$

The q -grammar framework gives rise to several interesting combinatorial problems, which we formulate below:

- *Terms*: Characterize the words $w \in F(\mathbb{S})$ appearing in (3.5) for which $a_w \neq 0$. These words are called *terms* of the q -derivative.
- *Number of terms*: Determine the cardinality of the set of terms.
- *Coefficients*: Obtain explicit formulas for the coefficients a_w .

- *Combinatorial model*: Provide a combinatorial interpretation for the coefficients a_w .
- *Generating functions*:
 - (1) Determine an appropriate evaluation map ϕ such that $\phi(D^k(f))$ admits a simple closed form;
 - (2) Develop a general method, which we refer to as *q-grammar calculus*, to compute the *q*-exponential generating functions for $\phi(D^k(f))$.

3.9. A canonical example. Take the grammar $G_{\tan \cup \sec}$ defined in (3.1):

$$G_{\tan \cup \sec} = (\{x, y\}, \{x_j \rightarrow q^j(1 + x_j x_{j+1}), y_j \rightarrow q^j x_j y_{j+1}\}, \mathbf{DIO}). \quad (3.6)$$

We have

$$\begin{aligned} D^0(x_0) &= x_0, \\ D^1(x_0) &= 1 + x_1 x_0, \\ D^2(x_0) &= (1 + q)x_1 + x_1^2 x_0 + q x_2 x_1^2, \\ D^3(x_0) &= (q + q^2) + (1 + q)x_1^2 + x_1^3 x_0 + (q^2 + q^3)x_2^2 \\ &\quad + (q + q^2)x_2^2 x_1^2 + q x_2 x_1^3 + (2q^2 + 2q)x_2 x_1 + q^2 x_2^3 x_1 + q^3 x_3 x_2^3, \\ D^0(y_0) &= y_0 \\ D^1(y_0) &= y_1 x_0 \\ D^2(y_0) &= q y_2 x_1^2 + y_1 + x_1 y_1 x_0 \\ D^3(y_0) &= q^3 y_3 x_2^3 + q^2 x_2 y_2 + q^2 x_2^2 y_2 x_1 + (q^2 + 2q) y_2 x_1 \\ &\quad + (q^2 + q) x_2 y_2 x_1^2 + q y_2 x_1^3 + x_1 y_1 + x_1^2 y_1 x_0. \end{aligned}$$

Let D be formal q -derivative associated with $G_{\tan \cup \sec}$ given by (3.6) and define

$$D^n(x_0) = \sum_{w \in F(\mathbb{S})} a_w w. \quad (3.7)$$

We have the following two consequences concerning the terms and the number of terms in (3.7). However, no explicit closed-form expression for the coefficients a_w has yet been established.

Proposition 3.8. *For $n \geq 3$, every term in (3.7) takes exactly one of the following three forms:*

- (i) $x_n x_{n-1}^n$;
- (ii) $x_1^n x_0$;
- (iii) $x_{j+1}^a x_j^b$, where $a, b \leq n$, $1 \leq j \leq n-2$, $a+b \leq n+1$, and $a+b+n+1$ is even.

Proof. We prove by induction on n . For $n = 3$, a direct computation verifies that the statement holds. Assume the proposition holds for $n - 1$ (with $n - 1 \geq 3$). That is, every term in $D^{n-1}(x_0)$ is of one of the forms (i)–(iii) with n replaced by $n - 1$. Applying the operator D to such a term and using the grammar rule $D(x_j) = q^j(1 + x_j x_{j+1})$, we obtain new terms. By a straightforward case analysis, one can verify that each resulting term again fits one of the forms (i)–(iii) for the index n .

Conversely, to show that every term of the forms (i)–(iii) for index n indeed appears in $D^n x_0$, we construct a preimage in $D^{n-1} x_0$ for each case.

- **Case (i):** $x_n x_{n-1}^n$. Consider the term $x_{n-1} x_{n-2}^{n-1}$ in $D^{n-1} x_0$. Applying D yields that $D(x_{n-1} x_{n-2}^{n-1})$ contains

$$D(x_{n-1}) x_{n-2}^{n-1} = q^{n-1}(1 + x_n x_{n-1}) x_{n-2}^{n-1} = q^{n-1} x_{n-2}^{n-1} + q^{n-1} x_n x_{n-2}^{n-1}.$$

The second term (up to the scalar factor q^{n-1}) is exactly $x_n x_{n-2}^{n-1}$.

- **Case (ii):** $x_1^n x_0$. Take the term $x_1^{n-1} x_0$ in $D^{n-1} x_0$. Then $D(x_1^{n-1} x_0)$ contains

$$x_1^{n-1} D(x_0) = x_1^{n-1}(1 + x_1 x_0) = x_1^{n-1} + x_1^n x_0,$$

where the second summand gives the desired term.

- **Case (iii):** $x_{j+1}^a x_j^b$ with $1 \leq j \leq n-2$, $a+b \leq n+1$, $2 \mid (a+b+n+1)$, and $a, b \leq n$. We split into subcases according to the parity and size conditions. In each subcase, we exhibit a suitable term in $D^{n-1} x_0$ whose D -image contains $x_{j+1}^a x_j^b$.

- (1) If $a + b = n + 1$ and $a \geq 2$, then $x_{j+1}^a x_j^b$ appears as a term in $D(x_{j+1}^{a-1} x_j^b)$.
- (2) If $a + b = n + 1$ and $a = 1$, then $x_{j+1}^1 x_j^b$ can be obtained from $D(x_j^{n-1} x_{j-1})$ (note that $b = n$ in this situation).
- (3) If $a + b < n + 1$ and $b \neq n - 1$, then $x_{j+1}^a x_j^b$ is a term in $D(x_{j+1}^a x_j^{b+1})$.
- (4) If $a + b < n + 1$ and $b = n - 1$, then $x_{j+1}^a x_j^{n-1}$ appears in $D(x_j x_{j-1}^b)$ (with j replaced appropriately).

In each subcase, the chosen preimage lies in $D^{n-1} x_0$ by the induction hypothesis, and a direct application of D verifies the claim.

The combination of the forward and backward arguments completes the induction, establishing the proposition. \square

The following proposition determine the number of terms in (3.7). Here and in the sequel, we define $\Omega(D^k(f))$ to denote the total number of terms of the expression in $D^k(f)$, where the term-counting operator $\Omega: \mathbb{E} \rightarrow \mathbb{N}$ returns the cardinality of the term set of a given polynomial. For the examples presented at the beginning of this subsection, we have $\Omega(D^2(x_0)) = 3$

and $\Omega(D^3(x_0)) = 9$. The general expressions are stated in the following proposition.

Proposition 3.9. *Let D be formal q -derivative associated with $G_{\tan \cup \sec}$ given by (3.6). For $n \geq 3$,*

$$\Omega(D^n(x_0)) = \begin{cases} 2k^3 + 5k^2 + 2, & \text{if } n = 2k + 1, \\ (k + 2)(2k^2 - 2k + 1), & \text{if } n = 2k. \end{cases}$$

Proof. We treat the two parity cases separately.

Case 1: $n = 2k + 1$. From Proposition 3.8, we have:

- One term of type (i): $x_n x_{n-1}^n$.
- One term of type (ii): $x_1^n x_0$.
- Type (iii) contributions: For $1 \leq j \leq n - 2 = 2k - 1$, the pairs (a, b) satisfies $a + b \leq n + 1 = 2k + 2$, $a, b \leq n = 2k + 1$, and $2 \mid (a + b + n + 1) = a + b + 2k + 2$. The parity condition simplifies to $a + b$ being even. Let $a + b = 2d$. Then $0 \leq d \leq k + 1$. A direct enumeration yields that the number of such terms equals $2d(2k - 1) + 1$ when $0 \leq d \leq k$; and equals $(2k - 1)(2k + 1)$ when $d = k + 1$. Then the total number of such terms equals

$$(2k - 1)(2k + 1) + \sum_{d=0}^k (2d(2k - 1) + 1) = k + 1 + (2k - 1)(k^2 + 3k + 1).$$

Adding the two special terms yields the total

$$\Omega(D^{2k+1}(x_0)) = k + 3 + (2k - 1)(k^2 + 3k + 1).$$

Case 2: $n = 2k$. A similar counting argument, using the same lemma, gives

$$\Omega(D^{2k}(x_0)) = (k + 2)(2k^2 - 2k + 1).$$

The detailed enumeration is analogous to the odd case and is therefore omitted. \square

Concerning the combinatorial interpretation for the coefficient a_w in (3.7), we recast Theorem 1.1 of [24] within the framework of our q -grammar terminology. In [24], the authors introduce the notion of t -permutations and define two associated statistics, denoted “ides” and “imaj”. For the sake of preserving the continuity of our exposition, we do not reproduce these definitions here. For each triple (k, a, b) , let $\mathcal{T}_{n,k,a,b}$ denote the set of all t -permutations w for which $\text{ides } w = k$, subject to a number of additional structural constraints and let $\mathcal{T}_{n,k,a,b+1}^-$ denote the set of all t -permutations $w = (w_0, w_1, \dots, w_m, w_{m+1})$ in $\mathcal{T}_{n,k,a,b}$ such that $w_{m+1} = \epsilon$. The precise formulation of these constraints is given in [24, Subsections 1.3–1.5].

Theorem 3.10. [24, Theorem 1.1] *Let*

$$A_{n,k,a,b}(q) = \sum_{w \in \mathcal{T}_{n,k,a,b}} q^{\text{imaj } w}$$

and

$$B_{n,k,a,b}(q) = \sum_{w \in \mathcal{T}_{n,k,a,b+1}^{-1}} q^{\text{imaj } w}$$

Then

$$D^n(x_0) = \sum_{k,a,b} A_{n,k,a,b}(q) x_{k+1}^b x_k^a,$$

and

$$D^n(y_0) = \sum_{k,a,b} B_{n,k,a,b}(q) y_{k+1}^b x_{k+1}^a x_k^a,$$

where $0 \leq k \leq n - 1$ and $0 \leq a + b \leq n + 1$.

Using Theorem 3.10, Foata and Han [24] derived the following q -exponential generating functions.

Theorem 3.11. [24, Theorem 1.5] *Let $\phi = \{x_j \mapsto x, y_j \mapsto y\}$ denote the evaluation map that assigns to each variable x_j the variable x and each variable y_j the variable y . We have*

$$\sum_{n \geq 0} \phi(D^n(x_0)) \frac{u^n}{(q; q)_n} = \tan_q(u) + \frac{x \sec_q(u) \text{Sec}_q(u)}{1 - x \tan_q(u)}, \quad (3.8)$$

$$\sum_{n \geq 0} \phi(D^n(y_0)) \frac{u^n}{(q; q)_n} = \frac{y \sec_q(u)}{1 - x \tan_q(u)}. \quad (3.9)$$

These two identities are q -analogues of Hoffman's formula [36], which is commonly written in the form:

$$\sum_{n \geq 0} A_n(x) \frac{u^n}{n!} = \frac{x + \tan(u)}{1 - x \tan(u)},$$

$$\sum_{n \geq 0} B_n(x) \frac{u^n}{n!} = \frac{1}{\cos u - x \sin u}.$$

In Subsection 4.3, we present a grammatical derivation of Theorem 3.11 using the q -grammar calculus developed in Section 4. As shown in Subsection 4.3, this approach relies solely on the definition of the q -grammar $G_{\tan \cup \sec}$ given by (3.6) and the evaluation map ϕ defined in Theorem 3.11.

3.10. Further examples. By analogy with the example discussed in the preceding subsection, the following q -grammars are investigated in [24] within the framework of q -trigonometric functions.

$$\begin{aligned} G_{\tan} &= (\{x\}, \{x_j \rightarrow q^j(1 + x_j x_{j+1})\}, \mathbf{DIO}); \\ G_{\tan'} &= (\{x\}, \{x_j \rightarrow q^j(1 + x_j x_{j+1})\}, \mathbf{LPO}); \\ G_{\sec} &= (\{x, y\}, \{x_j \rightarrow q^j(1 + x_j x_{j+1}), y_j \rightarrow q^j x_j y_{j+1}\}, \mathbf{DIO}); \\ G_{\sec'} &= (\{x, y\}, \{x_j \rightarrow q^j(1 + x_j x_{j+1}), y_j \rightarrow q^j x_j y_{j+1}\}, \mathbf{LPO}); \\ G_{\text{Sec}} &= (\{x, y\}, \{x_j \rightarrow q^j(1 + x_j x_{j+1}), y_j \rightarrow q^j y_j x_{j+1}\}, \mathbf{DIO}); \\ G_{\text{Sec}'} &= (\{x, y\}, \{x_j \rightarrow q^j(1 + x_j x_{j+1}), y_j \rightarrow q^j y_j x_{j+1}\}, \mathbf{LPO}). \end{aligned}$$

The rules in the aforementioned q -grammars are motivated by the action of the q -derivative operator for the q -trigonometric functions \tan_q , \sec_q , and Sec_q , as described in Proposition 2.2. Specifically, we set

$$x_j := \tan_q(q^j u), \quad y_j := \sec_q(q^j u) \quad \text{or} \quad y_j := \text{Sec}_q(q^j u).$$

We do not reproduce here the results concerning these q -grammars. The reader is referred to [24] for a complete description and rigorous proofs of these results. We shall mention only one of them, which is related to Mahonian statistics. Consider the q -grammar $G_{\tan'}$. Then the coefficient of the monomial $x_0 x_1 x_2 \cdots x_n$ in $D^n(x_0)$ is given by

$$(1 + q)(1 + q + q^2) \cdots (1 + q + q^2 + \cdots + q^{n-1}).$$

3.11. Proposed new q -grammars. In this paper, we first develop a method for computing the q -exponential generating functions (4.2) associated with the corresponding q -grammars, which we refer to as q -grammar calculus. As an illustration of this method, we provide a grammatical derivation of q -binomial inversion formula (see Example 4.8). We also provide a grammatical derivation of Theorem 3.11 (see Subsection 4.3). We then introduce several new classes of q -grammars. Although the related problems posed in Section 3.8 could be investigated, our primary focus at the present paper is to construct a suitable evaluation map ϕ such that $\phi(D^k(s))$ yields several classical combinatorial polynomials, including two q -analogs of the Eulerian polynomials, q -analog of the Roselle polynomials and two q -analogs of the André polynomials. It is worth noting that, in most of our examples, the combinatorial interpretation of $\phi(D^k(s))$ relies on classical Mahonian statistics for permutations or trees, such as the *inversion number* (inv) and the *major index* (maj). See Section 5 and Section 6 for related definitions. More precisely,

Subsection 5.1. (des, maj) on permutations:

- $G_{\text{maj}} = (\{x, y\}, \{x_j \rightarrow q^j x_0 y_0, y_j \rightarrow q^j x_0 y_0\}, \mathbf{LPO})$,
- $\phi = \{x_j \rightarrow x q^j, y_j \rightarrow y q^j\}$.

Subsection 5.2. (des, inv) on permutations:

- $G_{\text{inv}} = (\{x, y\}, \{x_j \rightarrow q^j y_j x_{j+1}, y_j \rightarrow q^j y_j x_{j+1}\}, \mathbf{AIO})$,
- $\phi = \{x_j \rightarrow x, y_j \rightarrow y\}$.

Subsection 5.4. cycle q -Roselle polynomials:

- $G_{\text{cyc}} = (\{x, y, z, e\}, R, \mathbf{KSO})$, where
- $R = \{x_j \rightarrow q^j y_j x_{j+1}, y_j \rightarrow q^j y_j x_{j+1}, z_j \rightarrow q^j y_j x_{j+1}, e_j \rightarrow t q^j e_j z_{j+1}\}$,
- $\phi = \{x_j \rightarrow x, y_j \rightarrow y, z_j \rightarrow z, e_j \rightarrow e\}$.

Subsection 6.1. (des, inv) on André I permutations:

- $G_{\text{AndI}} = (\{x, y\}, \{x_j \rightarrow q^j x_j y_{j+1}, y_j \rightarrow q^j x_j\}, \mathbf{AIO})$,
- $\phi = \{x_j \rightarrow t, y_j \rightarrow 1\}$.

Subsection 6.2. (des, inv) on André II permutations:

- $G_{\text{AndII}} = (\{x, y\}, \{x_j \rightarrow q^j x_j y_{j+1}, y_j \rightarrow q^{j+1} x_{j+1}\}, \mathbf{AIO})$,
- $\phi = \{x_j \rightarrow t, y_j \rightarrow 1\}$.

4. q -GRAMMAR CALCULUS

This section aims to develop q -grammar calculus. Analogous to the grammar calculus presented in Appendix I, we define the q -exponential generating function of $f \in \mathbb{E}$ associated with the q -derivative associated with a q -grammar. More precisely, let $G = (S, R, \rho)$ be a q -grammar, and let D denote the q -derivative associated with G . For any $f \in \mathbb{E}$, we introduce the following q -exponential generating function:

$$\text{Gen}_q^{(G)}(f; u) = \sum_{n \geq 0} D^n(f) \frac{u^n}{(q; q)_n}. \quad (4.1)$$

Let ϕ be an evaluation map, define

$$\text{gen}_q(f, u) = \phi \left(\text{Gen}_q^{(G)}(f; u) \right) = \sum_{k \geq 0} \phi(D^k(f)) \frac{u^k}{(q; q)_k}. \quad (4.2)$$

The formal power series $\text{Gen}_q^{(G)}(f; u)$ and $\text{gen}_q(f, u)$ are also referred to as the Eulerian generating function; see Goldman and Rota [34]. This may be viewed as a q -analogue of the exponential generating function associated with the grammar defined in (I.4), as detailed in Appendix I. The exponential generating function associated with a classical grammar plays a fundamental role in the grammar calculus developed by Chen [5]. To establish q -grammar calculus, we investigate the properties of the q -exponential generating functions (4.1) and (4.2). It transpires that the q -exponential

generating function exhibits richer structure, particularly with regard to the multiplicative property (I.6).

This section is structured as follows. In Subsection 4.1, we establish several properties of the q -derivative associated with a q -grammar. Specifically, we derive the q -Leibniz formula for q -derivatives associated with a special class of q -grammars (termed q -linear grammars). As an application, we provide a grammatical derivation of the q -binomial inversion formula. Subsection 4.2 is devoted to studying the q -exponential generating function (4.1) and (4.2) using the properties of the q -derivative developed in the previous subsection. We establish the multiplicative property of the q -exponential generating function (4.2) under restricted evaluation maps and q -grammars, as summarized in Theorem 4.14. In Subsection 4.3, we illustrate the use of q -grammar calculus by deriving q -Hoffman's formula (Theorem 3.11) as an application of Theorem 4.14.

For the convenience of reference, we collect the relevant formulas concerning q -derivative and its q -exponential generating function in Appendix II.

4.1. Properties of the q -derivative. Recall that \mathbb{E} denotes group algebra $\mathbb{K}[q][F(\mathbb{S})]$ on $F(\mathbb{S})$, where $F(\mathbb{S})$ denotes the free group on \mathbb{S} . Since D is a linear operator (see Definition 3.6), the following proposition is obvious:

Proposition 4.1. *For $f, g \in \mathbb{E}$ and $c \in \mathbb{K}[q]$, we have*

$$\begin{aligned} D(c) &= 0, \\ D(cf) &= cD(f), \\ D(f + g) &= D(f) + D(g). \end{aligned}$$

Unlike the usual product rule for derivatives, the q -derivative satisfies the following modified product rule:

Proposition 4.2. *For $f, g \in \mathbb{E}$, we have:*

$$D(fg) = D(f) \uparrow g + fD(g). \quad (4.3)$$

Proof. Since D is a linear operator, it is sufficient to show that (4.3) holds for $f, g \in F(\mathbb{S})$. Assume that $f = w_1 w_2 \cdots w_n$ and $g = w_{n+1} w_{n+2} \cdots w_{n+m}$ where each $w_i \in \mathbb{S} \cup \mathbb{S}^{-1}$. Then

$$\begin{aligned} & D(f) \uparrow g + fD(g) \\ &= D(w_1 w_2 \cdots w_n) \uparrow (w_{n+1} w_{n+2} \cdots w_{n+m}) + w_1 w_2 \cdots w_n D(w_{n+1} \cdots w_{n+m}) \\ &= \sum_{j=1}^n \left(w_1 w_2 \cdots w_{j-1} R(w_j) \uparrow (w_{j+1} \cdots w_n) \right) \uparrow (w_{n+1} w_{n+2} \cdots w_{n+m}) \end{aligned}$$

$$\begin{aligned}
 & + w_1 w_2 \cdots w_n \sum_{j=1}^m \left(w_{n+1} w_{n+2} \cdots w_{n+j-1} R(w_{n+j}) \uparrow (w_{n+j+1} \cdots w_{n+m}) \right) \\
 & = \sum_{j=1}^{m+n} \left(w_1 w_2 \cdots w_{j-1} R(w_j) \uparrow (w_{j+1} \cdots w_{m+n}) \right) \\
 & = D(w_1 w_2 \cdots w_{m+n}) \\
 & = D(fg),
 \end{aligned}$$

as desired. This completes the proof. \square

By induction, one easily derives the following result.

Proposition 4.3. *For any $f_i \in \mathbb{E}$ ($1 \leq i \leq n$), we have*

$$D(f_1 f_2 \cdots f_n) = \sum_{j=1}^n f_1 f_2 \cdots f_{j-1} D(f_j) \uparrow (f_{j+1} \cdots f_n).$$

The following proposition describes how to compute the q -derivative of the inverse of $f \in F(\mathbb{S})$.

Proposition 4.4. *Let $f \in F(\mathbb{S})$, we have*

$$D(f^{-1}) = -f^{-1} D(f) \uparrow (f^{-1}).$$

Proof. Suppose that $f = w_1 w_2 \cdots w_n$ where each $w_i \in \mathbb{S} \cup \mathbb{S}^{-1}$. Then $f^{-1} = w_n^{-1} w_{n-1}^{-1} \cdots w_1^{-1}$ and so

$$\begin{aligned}
 & f^{-1} D(f) \uparrow (f^{-1}) \\
 & = f^{-1} \sum_{j=1}^n w_1 w_2 \cdots w_{j-1} R(w_j) \uparrow (w_{j+1} \cdots w_n) \uparrow (w_n^{-1} w_{n-1}^{-1} \cdots w_1^{-1}) \\
 & = \sum_{j=1}^n w_n^{-1} w_{n-1}^{-1} \cdots w_{j+1}^{-1} w_j^{-1} R(w_j) \uparrow (w_j^{-1} w_{j-1}^{-1} \cdots w_1^{-1}) \\
 & = - \sum_{j=1}^n w_n^{-1} w_{n-1}^{-1} \cdots w_{j+1}^{-1} R(w_j^{-1}) \uparrow (w_{j-1}^{-1} \cdots w_1^{-1}) \\
 & = -D(w_n^{-1} w_{n-1}^{-1} \cdots w_1^{-1}) \\
 & = -D(f^{-1}),
 \end{aligned}$$

which completes the proof. \square

Because the q -derivative does not adhere to the classical product rule, the q -Leibniz formula (q -analogue of (I.3)) is not satisfied for general q -grammars. We find that it holds for a special case of q -grammars, which we define as q -linear grammars.

Definition 4.5 (*q*-Linear grammar). A *q*-grammar $G = (S, R, \rho)$ is called *q*-linear if $\rho = \mathbf{KSO}$, and for each master variable $s \in \mathbb{S}$ and any $i \geq 0$, we have

$$R(s_{i+1}) = R(\uparrow s_i) = q \uparrow R(s_i). \quad (4.4)$$

For example, the *q*-grammar G_{cyc} defined in Subsection 5.4 is *q*-linear.

For a *q*-linear grammar, we have the following consequence.

Proposition 4.6. *Let G be a q -linear grammar and let D be q -derivative associated with G . For $m, n \geq 1$ and $f \in \mathbb{E}$, we have*

$$D^n(\uparrow^m f) = q^{nm} \uparrow^m (D^n(f)). \quad (4.5)$$

Proof. Just need to prove the case $m = n = 1$ and $f \in \mathbb{S} \cup \mathbb{S}^{-1}$, which is easy to verify by the definition of *q*-linear grammar and Proposition 4.3. \square

Using Proposition 4.6, we derive the following *q*-Leibniz formula for the *q*-derivative associated with a *q*-linear grammar. Recall that the *q*-binomial coefficient (also called the Gaussian polynomial) is defined by

$$\begin{bmatrix} n+m \\ n \end{bmatrix}_q = \begin{cases} \frac{(1-q^{n+m})(1-q^{n+m-1}) \cdots (1-q^{m+1})}{(1-q^n)(1-q^{n-1}) \cdots (1-q)}, & \text{for } n, m \geq 0, \\ 0, & \text{otherwise,} \end{cases}$$

see Andrews [2, Chapter 1].

Proposition 4.7. *Let G be a q -linear grammar and let D be q -derivative associated with G . For $n \geq 1$ and $f, g \in \mathbb{E}$, we have*

$$D^n(fg) = \sum_{k=0}^n \begin{bmatrix} n \\ k \end{bmatrix}_q D^k(f) \uparrow^k (D^{(n-k)}(g)), \quad (4.6)$$

Proof. We proceed by induction on n . The case $n = 1$ follows from Proposition 4.2. Assume that the identity in (4.6) holds for some n , that is,

$$D^n(fg) = \sum_{k=0}^n \begin{bmatrix} n \\ k \end{bmatrix}_q D_q^k(f) \uparrow^k (D^{(n-k)}(g)). \quad (4.7)$$

We now aim to show that the identity holds for $n + 1$. To do this, we apply *q*-derivative D to the both sides of (4.7):

$$\begin{aligned} & D^{n+1}(fg) \\ &= D \left(\sum_{k=0}^n \begin{bmatrix} n \\ k \end{bmatrix}_q D_q^k(f) \uparrow^k (D^{(n-k)}(g)) \right) \\ &\stackrel{(4.5)}{=} \sum_{k=0}^n \begin{bmatrix} n \\ k \end{bmatrix}_q D^{k+1}(f) \uparrow^{k+1} (D^{(n-k)}(g)) + \sum_{k=0}^n \begin{bmatrix} n \\ k \end{bmatrix}_q q^k D_q^k(f) \uparrow^k (D^{(n-k+1)}(g)) \end{aligned}$$

$$\begin{aligned}
 &= \sum_{k=1}^{n+1} \begin{bmatrix} n \\ k-1 \end{bmatrix}_q D^k(f) \uparrow^k \left(D^{(n-k+1)}(g) \right) + \sum_{k=0}^n \begin{bmatrix} n \\ k \end{bmatrix}_q q^k D_q^k(f) \uparrow^k \left(D^{(n-k+1)}(g) \right) \\
 &= D^{n+1}(f) \uparrow^{n+1} g + f D^{(n+1)}(g) \\
 &\quad + \sum_{k=1}^n \left(\begin{bmatrix} n \\ k-1 \end{bmatrix}_q + q^k \begin{bmatrix} n \\ k \end{bmatrix}_q \right) D^k(f) \uparrow^k \left(D^{(n-k+1)}(g) \right) \\
 &= D^{n+1}(f) \uparrow^{n+1} g + f D^{(n+1)}(g) + \sum_{k=1}^n \begin{bmatrix} n+1 \\ k \end{bmatrix}_q D^k(f) \uparrow^k \left(D^{(n-k+1)}(g) \right) \\
 &= \sum_{k=0}^{n+1} \begin{bmatrix} n+1 \\ k \end{bmatrix}_q D^k(f) \uparrow^k \left(D^{(n-k+1)}(g) \right),
 \end{aligned}$$

as desired. This completes the proof. \square

As an application of Proposition 4.7, we provide a grammatical derivation of the following q -binomial inversion [1, Corollary 3.38].

Example 4.8. Let a_0, a_1, a_2, \dots and b_0, b_1, b_2, \dots be two sequences. Then we have the following q -inversion pair:

$$(i). a_n = \sum_{k=0}^n \begin{bmatrix} n \\ k \end{bmatrix}_q b_k \iff (ii). b_n = \sum_{k=0}^n (-1)^{n-k} \begin{bmatrix} n \\ k \end{bmatrix}_q q^{\binom{n-k}{2}} a_k. \quad (4.8)$$

Proof. We consider the following q -linear grammar:

$$G_{\text{binv}} = (\{x, y\}, \{x_j \mapsto q^j x_{j+1}, y_j \mapsto q^j y_j\}, \mathbf{KSO}). \quad (4.9)$$

Let D be the q -derivative associated with G_{binv} . It is easy to check that for $n \geq 1$,

$$D^n(x_0) = q^{\binom{n}{2}} x_n, \quad D^n(y_0) = y_0. \quad (4.10)$$

Using Proposition 4.4, we have

$$D(y_i^{-1}) = -y_i^{-1} D(y_i) \uparrow (y_{i+1}^{-1}) = -q^i y_i^{-1} y_i y_{i+1}^{-1} = -q^i y_{i+1}^{-1}$$

So, by induction, we obtain that for $n \geq 0$,

$$D^n(y_0^{-1}) = (-1)^n q^{\binom{n}{2}} y_n^{-1}. \quad (4.11)$$

Since G_{binv} is q -linear grammar, and by Proposition 4.7, we find that

$$D^n(x_0 y_0) = \sum_{k=0}^n \begin{bmatrix} n \\ k \end{bmatrix}_q D^k(x_0) \uparrow^k \left(D^{n-k}(y_0) \right) = \sum_{k=0}^n \begin{bmatrix} n \\ k \end{bmatrix}_q q^{\binom{k}{2}} x_k y_k.$$

Denote b_i by $q^{\binom{i}{2}} x_i y_i$. Then, the first identity in (4.8) can be rewritten as

$$D^n(x_0 y_0) = a_n. \quad (4.12)$$

Now, suppose it is true. From Proposition 4.7, and using (4.10) and (4.11), we deduce that

$$\begin{aligned}
b_n &= y_n D^n(x_0) = y_n D^n(x_0 y_0 y_0^{-1}) \\
&= y_n \sum_{k=0}^n \begin{bmatrix} n \\ k \end{bmatrix}_q D^k(x_0 y_0) \uparrow^k \left(D^{n-k}(y_0^{-1}) \right) \\
&= y_n \sum_{k=0}^n \begin{bmatrix} n \\ k \end{bmatrix}_q a_k (-1)^{n-k} q^{\binom{n-k}{2}} y_n^{-1} \\
&= \sum_{k=0}^n \begin{bmatrix} n \\ k \end{bmatrix}_q (-1)^{n-k} q^{\binom{n-k}{2}} a_k.
\end{aligned}$$

The converse can be proved similarly. \square

4.2. q -Exponential generating function. This section is devoted to studying the q -exponential generating functions of $D^n(f)$ and $\phi(D^n(f))$, making use of the q -derivative properties established in the previous section.

Proposition 4.9. *Let $G = (S, R, \rho)$ be a q -grammar and let D be q -derivative associated with G . For $f, g \in \mathbb{E}$, we have*

$$\text{Gen}_q^{(G)}(f + g; u) = \text{Gen}_q^{(G)}(f; u) + \text{Gen}_q^{(G)}(g; u), \quad (4.13)$$

$$D_q \text{Gen}_q^{(G)}(f; u) = \text{Gen}_q^{(G)}(D(f); u), \quad (4.14)$$

where D_q is the real q -derivative operator defined in (2.1).

Proof. By the linearity of q -derivative associated with q -grammar, it is straightforward to verify (4.13). By definition, we have

$$\begin{aligned}
D_q \text{Gen}_q^{(G)}(f; u) &= \frac{1}{u} \left(\sum_{n \geq 0} D^n(f) \frac{u^n}{(q; q)_n} - \sum_{n \geq 0} D^n(f) \frac{(uq)^n}{(q; q)_n} \right) \\
&= \frac{1}{u} \sum_{n \geq 0} D^n(f) \frac{(1 - q^n)u^n}{(q; q)_n} \\
&= \sum_{n \geq 1} D^n(f) \frac{u^{n-1}}{(q; q)_{n-1}} \\
&= \sum_{n \geq 0} D^{n+1}(f) \frac{u^n}{(q; q)_n} \\
&= \text{Gen}_q^{(G)}(D(f); u).
\end{aligned}$$

\square

As said in Subsection 4.1, the q -Leibniz formula does not hold for q -derivatives associated with general q -grammars, but we show that it is valid for q -linear grammars. This will lead to the multiplicative property of q -exponential generating functions (4.1) associated with the q -linear grammar. We begin with the following proposition.

Proposition 4.10. *Let G be a q -linear grammar. For $m \geq 1$ and $f \in \mathbb{E}$,*

$$\text{Gen}(\uparrow^m f; u) = \uparrow^m \text{Gen}(f; uq^m).$$

Proof. Using Proposition 4.6, we have

$$\begin{aligned} \text{Gen}_q(\uparrow^m f; u) &= \sum_{n \geq 0} D^n(\uparrow^m f) \frac{u^n}{(q; q)_n} \\ &= \sum_{n \geq 0} (q^{nm} \uparrow^m D^n(f)) \frac{u^n}{(q; q)_n} \\ &= \sum_{n \geq 0} \uparrow^m D^n(f) \frac{(uq^m)^n}{(q; q)_n} \\ &= \uparrow^m \text{Gen}(f; uq^m), \end{aligned}$$

as required. □

The next proposition establishes the multiplicative property of q -exponential generating functions (4.1) associated with q -linear grammars.

Proposition 4.11. *Let G be a q -linear grammar and let D be q -derivative associated with G . For $f, g \in \mathbb{E}$, we have*

$$\text{Gen}_q^{(G)}(fg; u) = \sum_{k \geq 0} D^k(f) \frac{u^k}{(q; q)_k} \uparrow^k \text{Gen}_q^{(G)}(g; u). \quad (4.15)$$

Proof. By Proposition 4.7, we have

$$\begin{aligned} \text{Gen}_q^{(G)}(fg; u) &= \sum_{n=0}^{+\infty} D^n(fg) \frac{u^n}{(q; q)_n} \\ &= \sum_{n=0}^{+\infty} \left(\sum_{k=0}^n \begin{bmatrix} n \\ k \end{bmatrix}_q D^k(f) \uparrow^k (D^{n-k}(g)) \right) \frac{u^n}{(q; q)_n} \\ &= \sum_{k=0}^{+\infty} D^k(f) \frac{u^k}{(q; q)_k} \sum_{n=k}^{+\infty} \uparrow^k (D^{n-k}(g)) \frac{u^{n-k}}{(q; q)_{n-k}} \\ &= \sum_{k=0}^{+\infty} D^k(f) \frac{u^k}{(q; q)_k} \sum_{n=0}^{+\infty} \uparrow^k (D^n(g)) \frac{u^n}{(q; q)_n} \\ &= \sum_{k \geq 0} D^k(f) \frac{u^k}{(q; q)_k} \uparrow^k \text{Gen}_q^{(G)}(g; u), \end{aligned}$$

as desired. \square

We proceed to establish the multiplicative property of q -exponential generating functions (4.2) for q -linear grammars under a restricted class of evaluation maps.

Definition 4.12 (Master-linear evaluation). An evaluation map $\phi: \mathbb{S} \rightarrow \mathbb{V}$ is called master-linear if $\phi(s_i) = \phi(s_j)$ for each master variable $s \in S$ and any $i, j \geq 0$.

For illustration, the evaluation maps considered in Subsections 5.2, 5.4, 6.1 and 6.2 are master-linear, while the evaluation map considered in Subsection 5.1 fails to satisfy this condition.

By applying a master-linear evaluation ϕ to both sides of (4.15), we derive the following multiplicative property:

Proposition 4.13. *Let G be a q -linear grammar and let ϕ be a master-linear evaluation. For $f, g \in \mathbb{E}$, we have*

$$\phi\left(\text{Gen}_q^{(G)}(fg; u)\right) = \phi\left(\text{Gen}_q^{(G)}(f; u)\right) \cdot \phi\left(\text{Gen}_q^{(G)}(g; u)\right). \quad (4.16)$$

Furthermore, by induction, we obtain that for any $n > 0$,

$$\phi\left(\text{Gen}_q^{(G)}\left(\prod_{k=1}^n f_k; u\right)\right) = \prod_{k=1}^n \phi\left(\text{Gen}_q^{(G)}(f_k; u)\right). \quad (4.17)$$

From Proposition 4.13, we see that reordering the variables in $f \in \mathbb{E}$ does not change the q -exponential generating function of $\phi(D^n(f))$. This observation implies that the product formula (4.16) is not limited solely to q -linear grammar. In fact, it holds for more general classes of q -grammar than q -linear grammar when ϕ is a master-linear evaluation map, which yields the central result of our q -grammar calculus.

Theorem 4.14. *Let $G = (S, R, \rho)$ be a q -grammar satisfying (4.4), that is, for each $s_i \in \mathbb{S}$ and any $i \geq 0$, we have $R(s_{i+1}) = R(\uparrow s_i) = q \uparrow R(s_i)$. Let ϕ be a master-linear evaluation. For $f, g \in \mathbb{E}$, we have*

$$\phi\left(\text{Gen}_q^{(G)}(fg; u)\right) = \phi\left(\text{Gen}_q^{(G)}(f; u)\right) \cdot \phi\left(\text{Gen}_q^{(G)}(g; u)\right). \quad (4.18)$$

Theorem 4.14 is a consequence of Proposition 4.13 together with the proposition below.

Proposition 4.15. *Let $G = (S, R, \rho)$ be a q -grammar such that (4.4) holds and let $\hat{G} = (S, R, \mathbf{KSO})$ be its corresponding q -linear grammar. Let ϕ be a master-linear evaluation. For $f \in \mathbb{E}$, we have*

$$\phi\left(\text{Gen}_q^{(G)}(f; u)\right) = \phi\left(\text{Gen}_q^{(\hat{G})}(f; u)\right). \quad (4.19)$$

Proof. Let D_G and $D_{\hat{G}}$ be the q -derivatives associated with G and \hat{G} respectively. By definition, we have

$$D_G = \rho \circ D_{\hat{G}}.$$

To prove (4.19), it suffices to show that for $f \in \mathbb{E}$,

$$\phi(D_G^n(f)) = \phi(D_{\hat{G}}^n(f))$$

holds for $n \geq 0$.

We will prove a more general result:

$$\phi\left(\text{Gen}_q^{(\hat{G})}(D_G^n(f); u)\right) = \phi\left(\text{Gen}_q^{(\hat{G})}(D_{\hat{G}}^n(f); u)\right). \quad (4.20)$$

The case $n = 0$ is trivial. Suppose that (4.20) holds for some n . Then we consider the $n + 1$ case. First, (4.20) implies

$$\begin{aligned} \phi\left(\text{Gen}_q^{(\hat{G})}(D_{\hat{G}} \circ D_G^n(f); u)\right) &= \phi\left(\text{Gen}_q^{(\hat{G})}(D_{\hat{G}} \circ D_{\hat{G}}^n(f); u)\right) \\ &= \phi\left(\text{Gen}_q^{(\hat{G})}(D_{\hat{G}}^{n+1}(f); u)\right). \end{aligned} \quad (4.21)$$

On the other hand, by Proposition 4.13, we find that

$$\phi\left(\text{Gen}_q^{(\hat{G})}(\rho \circ D_{\hat{G}} \circ D_G^n(f); u)\right) = \phi\left(\text{Gen}_q^{(\hat{G})}(D_{\hat{G}} \circ D_G^n(f); u)\right),$$

which implies that

$$\phi\left(\text{Gen}_q^{(\hat{G})}(D_G^{n+1}(f); u)\right) = \phi\left(\text{Gen}_q^{(\hat{G})}(D_{\hat{G}} \circ D_G^n(f); u)\right). \quad (4.22)$$

Putting (4.21) and (4.22) together, we obtain

$$\phi\left(\text{Gen}_q^{(\hat{G})}(D_G^{n+1}(f); u)\right) = \phi\left(\text{Gen}_q^{(\hat{G})}(D_{\hat{G}}^{n+1}(f); u)\right), \quad (4.23)$$

which completes the proof. \square

4.3. A grammatical derivation of q -Hoffman's formula. Here we provide grammatical derivations of Theorem 3.11 based on the q -grammar calculus developed in this section.

Let D be q -derivative associated with $G_{\text{tan} \cup \text{sec}}$ defined in (3.6). Using Proposition 4.4, we have

$$\begin{aligned} D(y_0^{-1}) &= -y_0^{-1}D(y_0) \uparrow (y_0^{-1}) \\ &= -y_0^{-1}(x_0 y_1) y_1^{-1} \\ &= -y_0^{-1} x_0, \end{aligned}$$

Thus, by Proposition 4.2, we have

$$\begin{aligned} D(y_0^{-1} x_0) &= D(y_0^{-1}) x_1 + y_0^{-1} D(x_0) \\ &= -y_0^{-1} x_0 x_1 + y_0^{-1} (1 + x_0 x_1) \\ &= y_0^{-1}. \end{aligned}$$

By induction, we derive that for $n \geq 0$,

$$D^{2n}(y_0^{-1}) = (-1)^n y_0^{-1}, \quad D^{2n+1}(y_0^{-1}) = (-1)^{n+1} y_0^{-1} x_0.$$

and

$$D^{2n}(y_0^{-1} x_0) = (-1)^n y_0^{-1} x_0, \quad D^{2n+1}(y_0^{-1} x_0) = (-1)^n y_0^{-1}.$$

Consequently,

$$\begin{aligned} \text{Gen}_q(y_0^{-1}; u) &= \sum_{n=0}^{+\infty} D^n(y_0^{-1}) \frac{u^n}{(q; q)_n} \\ &= \sum_{n \geq 0} (-1)^n y_0^{-1} \frac{u^{2n}}{(q; q)_{2n}} + \sum_{n \geq 0} (-1)^{n+1} y_0^{-1} x_0 \frac{u^{2n+1}}{(q; q)_{2n+1}} \\ &= y_0^{-1} (\cos_q(u) - x_0 \sin_q(u)) \end{aligned} \quad (4.24)$$

and

$$\begin{aligned} \text{Gen}_q(y_0^{-1} x_0; u) &= \sum_{n=0}^{+\infty} D^n(y_0^{-1} x_0) \frac{u^n}{(q; q)_n} \\ &= \sum_{n \geq 0} (-1)^n y_0^{-1} x_0 \frac{u^{2n}}{(q; q)_{2n}} + \sum_{n \geq 0} (-1)^n y_0^{-1} \frac{u^{2n+1}}{(q; q)_{2n+1}} \\ &= y_0^{-1} (x_0 \cos_q(u) + \sin_q(u)). \end{aligned} \quad (4.25)$$

Grammatical Proofs of Theorem 3.11. Let ϕ denote the evaluation map that sends x_j to x and y_j to y . It is straightforward to verify that ϕ is a master-linear evaluation. Note that the grammar $G_{\tan \cup \sec}$ defined in (3.6) is not a q -linear grammar, as the order $\rho = \mathbf{DIO}$ violates the defining conditions of q -linearity; however, this grammar still satisfies (4.4). Hence, by Theorem 4.14, we conclude that

$$1 = \phi(\text{Gen}_q(y_0 y_0^{-1}; u)) = \phi(\text{Gen}_q(y_0; u)) \phi(\text{Gen}_q(y_0^{-1}; u)).$$

It implies that

$$\begin{aligned} \phi(\text{Gen}_q(y_0; u)) &= \sum_{k=0}^{+\infty} \phi(D^k(y_0)) \frac{u^k}{(q; q)_k} \\ &= \frac{1}{\phi(\text{Gen}(y_0^{-1}; u))} \\ &\stackrel{(4.24)}{=} \frac{y}{\cos_q(u) - x \sin_q(u)}, \end{aligned} \quad (4.26)$$

which can be shown to be equivalent to (3.9).

For (3.8), we find that

$$\begin{aligned}
 \phi(\text{Gen}_q(x_0; u)) &= \phi(\text{Gen}_q(y_0 y_0^{-1} x_0; u)) \\
 &= \phi(\text{Gen}_q(y_0; u)) \phi(\text{Gen}_q(y_0^{-1} x_0; u)) \\
 &\stackrel{(4.25)(4.26)}{=} \frac{y}{\cos_q(u) - x \sin_q(u)} \times y^{-1} (x \cos_q(u) + \sin_q(u)) \\
 &= \frac{x \cos_q(u) + \sin_q(u)}{\cos_q(u) - x \sin_q(u)} \\
 &= \frac{x + \tan_q(u)}{1 - x \tan_q(u)}.
 \end{aligned}$$

One can show that this is equivalent to (3.8). This completes the proof. \square

5. q -GRAMMARS FOR PERMUTATIONS

In this section, we construct q -analogues of the two grammars established by Dumont [19], which address enumeration problems connected to the classical Eulerian polynomials defined on the set of permutations.

Let \mathfrak{S}_n denote the set of permutations on $[n] := \{1, 2, \dots, n\}$. For a permutation $\sigma = \sigma_1 \cdots \sigma_n \in \mathfrak{S}_n$, we assume that a zero is patched at the beginning and at the end, that is, $\sigma_0 = \sigma_{n+1} = 0$. An index i is a descent if $\sigma_i > \sigma_{i+1}$; otherwise, i is called an ascent. Let $\text{des}(\sigma)$ count the number of descents of σ and let $\text{asc}(\sigma)$ count the number of ascents of σ . For $n \geq 1$, the bivariate Eulerian polynomials are defined by

$$A_n(x, y) = \sum_{\sigma \in \mathfrak{S}_n} x^{\text{asc}(\sigma)} y^{\text{des}(\sigma)}, \quad (5.1)$$

and the exponential generating function of Eulerian polynomials is well known:

$$\sum_{n=0}^{\infty} A_n(x, y) \frac{u^n}{n!} = \frac{x - y}{1 - x^{-1} y e^{(x-y)u}}. \quad (5.2)$$

Dumont [19] found the grammar (I.9) to generate the bivariate Eulerian polynomials $A_n(x, y)$ and Chen and Fu [6] provided a grammatical derivation of (5.2), see Appendix I.

For a permutation $\sigma = \sigma_1 \cdots \sigma_n \in \mathfrak{S}_n$, an index $1 \leq i \leq n$ is called an excedance if $\sigma_i > i$, or a drop if $\sigma_i < i$, or a fixed point if $\sigma_i = i$. Clearly, n cannot be an excedance and 1 cannot be a drop. The number of excedances, the number of drops and the number of fixed points of σ are denoted by $\text{exc}(\sigma)$, $\text{drop}(\sigma)$ and $\text{fix}(\sigma)$, respectively. A drop of a permutation is also called an anti-excedance.

The joint distribution of (exc, fix) was determined by Foata-Schützenberger [25], see also Shin-Zeng [54]. For $n \geq 1$, define

$$F_n(x, z) = \sum_{\sigma \in \mathfrak{S}_n} x^{\text{exc}(\sigma)} z^{\text{fix}(\sigma)}$$

and define $F_0(x, z) = 1$. Then

$$\sum_{n=0}^{\infty} F_n(x, z) \frac{u^n}{n!} = \frac{(1-x)e^{zu}}{e^{xu} - xe^u}.$$

Writing

$$F_n(x, y, z) = \sum_{\sigma \in \mathfrak{S}_n} x^{\text{exc}(\sigma)} y^{\text{drop}(\sigma)} z^{\text{fix}(\sigma)}$$

and $F_0(x, y, z) = 1$, (5) can be converted into the homogeneous form

$$\sum_{n=0}^{\infty} F_n(x, y, z) \frac{u^n}{n!} = \frac{(y-x)e^{zu}}{ye^{xu} - xe^{yu}}.$$

The cycle Roselle polynomials $F_n(x, y, z|\beta)$ are defined by

$$F_n(x, y, z|\beta) = \sum_{\sigma \in \mathfrak{S}_n} x^{\text{exc}(\sigma)} y^{\text{drop}(\sigma)} z^{\text{fix}(\sigma)} \beta^{\text{cyc}(\sigma)}. \quad (5.3)$$

Using the exponential formula, Ksavrelof-Zeng [42] found that

$$\sum_{n=0}^{\infty} F_n(x, y, z|\beta) \frac{u^n}{n!} = \left(\frac{(y-x)e^{zu}}{ye^{xu} - xe^{yu}} \right)^{\beta}. \quad (5.4)$$

Dumont [19] showed that the grammar given in (I.12) generates the polynomials $F_n(x, y, z)$, which he referred to as Roselle polynomials. Chen and Fu [8] provided a grammatical derivation of (5). Ma-Ma-Yeh-Yeh [46] found the grammar to generate cycle Roselle polynomials $F_n(x, y, z|\beta)$.

This section is devoted to establishing q -grammars for q -analogues of Eulerian polynomials (5.1) and cycle Roselle polynomials (5.3).

Several q -analogs of Eulerian polynomials with combinatorial meanings have been studied in the literature (see [4, 3, 31, 50, 52, 53]). In this section, we mainly provide q -grammars for q -maj-Eulerian polynomials and q -inv-Eulerian polynomials.

Recall that the *major index* $\text{maj}(\sigma)$ of a permutation $\sigma \in \mathfrak{S}_n$ is the sum of all the descents of σ , i.e.,

$$\text{maj}(\sigma) := \sum_{i: \sigma_i > \sigma_{i+1}} i.$$

The inversion statistic is defined by

$$\text{inv}(\sigma) = \#\{(i, j): i < j, \sigma_i > \sigma_j\}.$$

The q -maj-Eulerian polynomials are defined by:

$$A_n^{\text{maj}}(q; x, y) = \sum_{\sigma \in \mathfrak{S}_n} q^{\text{maj}(\sigma)} x^{\text{asc}(\sigma)} y^{\text{des}(\sigma)}. \quad (5.5)$$

The q -inv-Eulerian polynomials are defined by:

$$A_n^{\text{inv}}(q; x, y) = \sum_{\sigma \in \mathfrak{S}_n} q^{\text{inv}(\sigma)} x^{\text{asc}(\sigma)} y^{\text{des}(\sigma)}. \quad (5.6)$$

To introduce the q -analogue of cycle Roselle polynomials, let us first interpret Roselle polynomials $F_n(x, y, z)$ based on the one-line representation of permutations. Let $\sigma = \sigma_1 \cdots \sigma_n \in \mathfrak{S}_n$. We first place a bar after each right-to-left minimum of σ and place a bar at the beginning of σ . Recall that a right-to-left minimum of σ is an element σ_i such that $\sigma_i < \sigma_j$ for every $j > i$. For the permutation $\sigma = 54127369108$, we have

$$\sigma = | 541 | 2 | 73 | 6 | 9108 | .$$

If there is only one element σ_j between two bars, then we call σ_j an isolated element. The number of isolated elements of σ is denoted by $\text{isol}(\sigma)$.

In order to single out ascents that are not isolated elements, we say that an index $0 \leq i \leq n-1$ of σ is a non-isolated ascent if i is an ascent and σ_{i+1} is not isolated. The number of non-isolated ascents of σ is denoted by $\text{iasc}(\sigma)$. It is easy to check that

$$\text{iasc}(\sigma) + \text{isol}(\sigma) = \text{asc}(\sigma).$$

We now construct a bijection ψ on \mathfrak{S}_n . Let $\sigma \in \mathfrak{S}_n$. Take the cycle decomposition of σ such that cycles are written with their smallest element last and the cycles are written in increasing order of their smallest element. Then erasing the parentheses yields $\tau = \psi(\sigma)$.

For example, let $\sigma = 52714639108$ and we adopt the following cycle form of σ : $(541)(2)(73)(6)(9108)$. Then $\tau = \psi(\sigma) = 54127369108$.

It is easy to check that

$$\begin{aligned} \text{drop}(\sigma) &= \text{des}(\tau) - 1, \\ \text{exc}(\sigma) &= \text{iasc}(\tau), \\ \text{fix}(\sigma) &= \text{isol}(\tau), \\ \text{cyc}(\sigma) &= \text{RLmin}(\tau). \end{aligned}$$

Note that the map ψ can be viewed as a variation of Foata's first fundamental transformation [25].

Hence, cycle Roselle polynomials (5.3) can be interpreted as

$$F_n(x, y, z|\beta) = \sum_{\sigma \in \mathfrak{S}_n} x^{\text{iasc}(\sigma)} y^{\text{des}(\sigma)-1} z^{\text{isol}(\sigma)} \beta^{\text{RLmin}(\sigma)}. \quad (5.7)$$

Based on the definition (5.7) of cycle Roselle polynomials, we consider the following cycle q -inv-Roselle polynomials

$$F_n^{\text{inv}}(q; x, y, z|\beta) = \sum_{\sigma \in \mathfrak{S}_n} q^{\text{inv}(\sigma)} x^{\text{iasc}(\sigma)} z^{\text{isol}(\sigma)} y^{\text{des}(\sigma)-1} \beta^{\text{RLmin}(\sigma)}. \quad (5.8)$$

The main objective of this section is to establish q -grammars for the q -maj-Eulerian polynomials (5.5), the q -inv-Eulerian polynomials (5.6) and the q -inv-Roselle polynomials (5.8). Our proofs rely on the grammatical labeling technique introduced by Chen and Fu [6]. As outlined in Appendix I, grammatical labeling exhibits how the substitution rules in context-free grammar arise in the construction of the combinatorial structures. Furthermore, this technique carries over naturally to the q -grammar context.

Harnessed by these q -grammars, we develop a q -calculus to derive the q -exponential generating functions for the q -inv-Eulerian polynomials (5.6) and the q -inv-Roselle polynomials (5.8) based on the framework developed in Section 4. The resulting identities serve as the q -analogues of (5.2) and (5.4). Setting $x = 1$ in Theorem 5.1, we recover the q -analogue of the generating function of Eulerian polynomials due to Stanley [57].

Theorem 5.1. *We have*

$$\sum_{n=0}^{\infty} A_n^{\text{inv}}(q; x, y) \frac{u^n}{(q; q)_n} = \frac{x - y}{1 - x^{-1} y e_q((x - y)u)}, \quad (5.9)$$

where $e_q(u)$ is given by (2.4).

Theorem 5.2. *We have*

$$\begin{aligned} & \sum_{n=0}^{\infty} F_n^{\text{inv}}(q; x, y, z|\beta) \frac{u^n}{(q; q)_n} \\ &= \prod_{k=0}^{+\infty} \frac{1 - x^{-1} y e_q((x - y)uq^{k+1})}{1 - \beta u q^k (z - y) - x^{-1} y (1 + \beta u q^k (x - z)) e_q((x - y)uq^{k+1})}, \end{aligned} \quad (5.10)$$

where $e_q(u)$ is defined in (2.4).

The rest of this section is organized as follows. Subsection 5.1 presents a q -grammar for the q -maj-Eulerian polynomials (5.5), as shown in Theorem 5.3; Subsection 5.2 provides a q -grammar for the q -inv-Eulerian polynomials (5.6), as described in Theorem 5.4; Based on Theorem 5.4, Subsection 5.3 delivers a grammatical derivation of Theorem 5.1. Subsection 5.4 introduces a q -grammar for the q -inv-Roselle polynomials (5.8) (see Theorem 5.8). Subsequently, relying on the result of Theorem 5.8, Subsection 5.5 derives Theorem 5.2 in a purely grammatical manner within the q -calculus framework.

5.1. q -Grammar for q -maj-Eulerian polynomials. We have the following consequence.

Theorem 5.3. *Let G_{maj} be the q -grammar defined by*

$$G_{\text{maj}} = (\{x, y\}, \{x_j \mapsto q^j x_0 y_0, y_j \mapsto q^j x_0 y_0\}, \mathbf{LPO}). \quad (5.11)$$

Let D be the q -derivative associated with G_{maj} and define the evaluation map ϕ by $\phi(x_j) = xq^j$ and $\phi(y_j) = yq^j$. Then

$$\phi(D^n(x_0)) = A_n^{\text{maj}}(q; x, y).$$

Proof. Let $\sigma = \sigma_1 \cdots \sigma_n \in \mathfrak{S}_n$. We first define the grammatical labeling of σ . Note that in the grammatical labeling of σ , descent positions are labeled by y and ascent positions are labeled by x . The subscripts of the x -labels are nonincreasing from left to right, and the subscripts of the y -labels are nondecreasing from left to right. The weight $\omega(\sigma)$ of σ is defined as the product of the labels in its grammatical labeling, taken according to the Letter-Priority Order (LPO).

The grammatical labeling of σ is defined recursively below. Successively remove the entries $n, n-1, \dots, m+1$ from σ to obtain the increasing sequence $\sigma^{(0)} = 1, 2, \dots, m$. Adjoin 0 at both ends of $\sigma^{(0)}$.

First, for $1 \leq i \leq m$, label the position immediately before $\sigma_i^{(0)}$ by x_0 , and label the position after $\sigma_m^{(0)}$ by y_0 . That is,

$$\sigma^{(0)} = 0 \quad x_0 \quad \sigma_1^{(0)} \quad x_0 \quad \sigma_2^{(0)} \quad x_0 \quad \cdots \quad \sigma_m^{(0)} \quad y_0 \quad 0.$$

In this case, the weight of $\sigma^{(0)}$ is

$$\omega(\sigma^{(0)}) = x_0^m y_0.$$

Let $\sigma^{(1)}$ be the permutation obtained from σ by removing $n, n-1, \dots, m+2$, and suppose that $m+1$ is inserted into $\sigma^{(0)}$ at position p to yield $\sigma^{(1)}$.

There are two cases:

Case 1: If $1 \leq p \leq m$, then position p of $\sigma^{(1)}$ is labeled x_0 and position $p+1$ is labeled y_0 . The subscripts of all labels before position p are increased by 1, and y_0 is changed to y_1 . Explicitly,

$$\sigma^{(1)} = 0 \quad x_1 \quad \sigma_1^{(0)} \quad \cdots \quad x_1 \quad m+1 \quad y_0 \quad \sigma_p^{(0)} \quad x_0 \quad \cdots \quad \sigma_m^{(0)} \quad y_1 \quad 0.$$

In this case, the weight of $\sigma^{(1)}$ is

$$\omega(\sigma^{(1)}) = x_0^p x_1^{m-p} y_0 y_1.$$

Case 2: If $p = m+1$, then position $m+1$ of $\sigma^{(1)}$ is labeled x_0 and position $m+2$ is labeled y_0 , while the subscripts of all remaining labels remain unchanged. That is,

$$\sigma^{(1)} = 0 \quad x_0 \quad \sigma_1^{(0)} \quad x_0 \quad \sigma_2^{(0)} \quad x_0 \quad \cdots \quad \sigma_m^{(0)} \quad x_0 \quad m+1 \quad y_0 \quad 0.$$

In this case, the weight of $\sigma^{(1)}$ is

$$\omega(\sigma^{(1)}) = x_0^{m+1} y_0.$$

Now let $\sigma^{(l)}$ be the permutation obtained from σ by removing $n, n-1, \dots, m+l+1$, where $0 \leq l < n-m$, and assume that $\sigma^{(l)}$ has been labeled recursively. Assume that the weight of $\sigma^{(l)}$ is

$$\omega(\sigma^{(l)}) = q^{s(\sigma^{(l)})} \omega_1(\sigma^{(l)}) \cdots \omega_{m+l+1}(\sigma^{(l)}).$$

We now define the grammatical labeling of $\sigma^{(l+1)}$. Note that $\sigma^{(l+1)}$ has $m+l+2$ positions to be labeled. As before, descent positions are labeled by y and ascent positions are labeled by x . The subscripts are determined as follows. Suppose that $m+l+1$ is inserted into $\sigma^{(l)}$ at position p to form $\sigma^{(l+1)}$, and

We consider two cases.

Case 1: Suppose position p in the labeling of $\sigma^{(l)}$ carries the label x_i , i.e., $\omega_j = x_i$ for some j . Then the subscripts of all labels of $\sigma^{(l)}$ before position p are increased by 1, and the subscripts of all y -labels of $\sigma^{(l)}$ after position p are increased by 1. Collect all resulting labels together with x_0 and y_0 , and rearrange them so that the x -subscripts are nonincreasing from left to right and the y -subscripts are nondecreasing from left to right. Label q^i below $\sigma_p^{(l)}$.

Case 2: Suppose position p in the labeling of $\sigma^{(l)}$ carries the label y_i , i.e., $\omega_j = y_i$ for some j . Then the subscripts of all y -labels of $\sigma^{(l)}$ after position p are increased by 1. Again, collect all resulting labels together with x_0 and y_0 , and rearrange them so that the x -subscripts are nonincreasing from left to right and the y -subscripts are nondecreasing from left to right. Label q^i below $\sigma_p^{(l)}$.

Below we illustrate the grammatical labeling for the permutation $\sigma = 12683574 \in \mathfrak{S}_8$:

$$\sigma^{(0)} = 0 \quad x_0 \quad 1 \quad x_0 \quad 2 \quad x_0 \quad 3 \quad x_0 \quad 4 \quad y_0 \quad 0$$

$$\sigma^{(1)} = 0 \quad x_1 \quad 1 \quad x_1 \quad 2 \quad x_1 \quad 3 \quad x_0 \quad \boxed{5} \quad y_0 \quad 4 \quad y_1 \quad 0$$

$$\sigma^{(2)} = 0 \quad x_2 \quad 1 \quad x_1 \quad \boxed{6} \quad y_0 \quad 2 \quad x_0 \quad 3 \quad x_0 \quad 5 \quad y_1 \quad 4 \quad y_2 \quad 0$$

q

$$\sigma^{(3)} = 0 \quad x_2 \quad 1 \quad x_1 \quad 6 \quad y_0 \quad 2 \quad x_0 \quad 3 \quad x_0 \quad 5 \quad x_0 \quad \boxed{7} \quad y_0 \quad 4 \quad y_3 \quad 0$$

$q \qquad \qquad \qquad q$

$$\sigma^{(4)} = 0 \quad x_1 \quad \boxed{8} \quad y_0 \quad 1 \quad x_0 \quad 6 \quad y_1 \quad 2 \quad x_0 \quad 3 \quad x_0 \quad 5 \quad x_0 \quad 7 \quad y_1 \quad 4 \quad y_4 \quad 0$$

$q^2 \qquad \qquad \qquad q \qquad \qquad \qquad q$

The weight $\omega(\sigma)$ of σ is defined as the product of all labels, read from right to left. For the above example, we have

$$\omega(\sigma) = q^4 x_0 x_0 x_0 x_0 x_1 y_0 y_1 y_1 y_4.$$

Recall that the morphism map ϕ is defined by $\phi(x_j) = xq^j$ and $\phi(y_j) = yq^j$. It is clear that

$$\phi(\omega(\sigma^{(0)})) = q^{\text{maj}(\sigma^{(0)})} x^{\text{asc}(\sigma^{(0)})} y^{\text{des}(\sigma^{(0)})}$$

and

$$\phi(\omega(\sigma^{(1)})) = q^{\text{maj}(\sigma^{(1)})} x^{\text{asc}(\sigma^{(1)})} y^{\text{des}(\sigma^{(1)})}.$$

By induction, we show that for all $0 \leq l \leq n - m$,

$$\phi(\omega(\sigma^{(l)})) = q^{\text{maj}(\sigma^{(l)})} x^{\text{asc}(\sigma^{(l)})} y^{\text{des}(\sigma^{(l)})}. \quad (5.12)$$

With this grammatical labeling, we now prove Theorem 5.3. By (5.12), it suffices to establish the identity: for $n \geq 1$,

$$D^n(x_0) = \sum_{\sigma \in \mathfrak{S}_n} \omega(\sigma), \quad (5.13)$$

where D is the q -derivative associated with the q -grammar (5.11).

Represent a permutation $\sigma = \sigma_1 \cdots \sigma_n \in \mathfrak{S}_n$ by adjoining 0 at both ends, creating $n + 1$ positions between consecutive elements. These positions are where we insert $n + 1$ to generate permutations in \mathfrak{S}_{n+1} . Assume that the weight of σ is

$$\omega(\sigma) = q^{s(\sigma)} \omega_1(\sigma) \cdots \omega_{n+1}(\sigma).$$

Let $\pi^{(i)} \in \mathfrak{S}_{n+1}$ be the permutation obtained by inserting $n + 1$ into σ at the position with label $\omega_i(\sigma)$. By the q -product formula,

$$D(\omega(\sigma)) = \sum_{i=1}^{n+1} q^{s(\sigma)} \rho\left(\omega_1(\sigma) \cdots \omega_{i-1}(\sigma) R(\omega_i(\sigma)) \uparrow (\omega_{i+1}(\sigma) \cdots \omega_{n+1}(\sigma))\right). \quad (5.14)$$

From the above grammatical labeling, it is straightforward to verify that

$$\begin{aligned} & q^{s(\sigma)} \rho\left(\omega_1(\sigma) \cdots \omega_{i-1}(\sigma) R(\omega_i(\sigma)) \uparrow (\omega_{i+1}(\sigma) \cdots \omega_{n+1}(\sigma))\right) \\ &= q^{s(\pi^{(i)})} \omega(\pi^{(i)}). \end{aligned}$$

Thus (5.14) holds, which implies that (5.13) is valid for $n + 1$. Theorem 5.3 now follows immediately from (5.12) and (5.13). \square

5.2. q -Grammar for q -inv-Eulerian polynomials.

Theorem 5.4. *Let G_{inv} be the q -grammar defined by*

$$G_{\text{inv}} = (\{x, y\}, \{x_j \rightarrow q^j y_j x_{j+1}, y_j \rightarrow q^j y_j x_{j+1}\}, \mathbf{AIO}). \quad (5.15)$$

Let D be the q -derivative associated with G_{inv} and define the evaluation map ϕ by $\phi(x_j) = x$ and $\phi(y_j) = y$. Then

$$\phi(D^n(x_0)) = A_n^{\text{inv}}(q; x, y). \quad (5.16)$$

Proof. Let $\sigma = \sigma_1 \cdots \sigma_n \in \mathfrak{S}_n$. For $1 \leq i \leq n+1$, recall that the position i is said to be the position immediately before σ_i , whereas the position $n+1$ is meant to be the position after σ_n . We patch 0 to σ at both ends so that there are $n+1$ positions between two adjacent elements. For $1 \leq i \leq n+1$, we label the position i of $\sigma \in \mathfrak{S}_n$ as follows:

- If i is an ascent, then label it by x_{n+1-i} ;
- If i is a descent, then label it by y_{n+1-i}

Below shows the grammatical labeling of a permutation $\sigma \in \mathfrak{S}_8$.

$$\sigma = 7 \ 1 \ 2 \ 8 \ 3 \ 6 \ 5 \ 4$$

$$\rightarrow 0 \ x_8 \ 7 \ y_7 \ 1 \ x_6 \ 2 \ x_5 \ 8 \ y_4 \ 3 \ x_3 \ 6 \ y_2 \ 5 \ y_1 \ 4 \ y_0 \ 0$$

The weight ω of σ is defined to be the product of all the labels from right to left. For the example above, we see that the weight of σ is

$$\omega(\sigma) = y_0 y_1 y_2 x_3 y_4 x_5 x_6 y_7 x_8.$$

We observe that

$$\phi \left(\sum_{\sigma \in \mathfrak{S}_n} q^{\text{inv}(\sigma)} \omega(\sigma) \right) = A_n^{\text{inv}}(q; x, y),$$

Thus, Theorem 5.4 follows once we confirm the assertion: For $n \geq 1$,

$$D^n(x_0) = \sum_{\sigma \in \mathfrak{S}_n} q^{\text{inv}(\sigma)} \omega(\sigma), \quad (5.17)$$

where D is q -derivative associated with q -grammar (5.15).

We proceed by induction on n . For $n = 1$, the statement is evident. Assume that this statement holds for n , that is, the relation (5.17) is valid for n . To demonstrate that it also holds for $n+1$, it suffices to show, by (5.17), that

$$D \left(\sum_{\sigma \in \mathfrak{S}_n} q^{\text{inv}(\sigma)} \omega(\sigma) \right) = \sum_{\pi \in \mathfrak{S}_{n+1}} q^{\text{inv}(\pi)} \omega(\pi). \quad (5.18)$$

For a permutation $\sigma \in \mathfrak{S}_n$, we define the weight

$$\omega(\sigma) = \omega_1(\sigma) \omega_2(\sigma) \cdots \omega_{n+1}(\sigma)$$

the product of the right-to-left labels in the grammatical labeling of σ .

Similarly, for the permutation $\pi \in \mathfrak{S}_{n+1}$, the weight is given by

$$\omega(\pi) = \omega_1(\pi)\omega_2(\pi) \cdots \omega_{n+2}(\pi)$$

the product of the right-to-left labels in the grammatical labeling of π .

Note that in this grammar, the order AIO is equivalent to KSO (Keep Sequence Order), and so by the q -product formula, we have

$$D(\omega(\sigma)) = \sum_{i=1}^{n+1} \omega_1(\sigma) \cdots \omega_{i-1}(\sigma) R(\omega_i(\sigma)) \uparrow (\omega_{i+1}(\sigma) \cdots \omega_{n+1}(\sigma)).$$

Next, we represent a permutation $\sigma = \sigma_1 \cdots \sigma_n$ in \mathfrak{S}_n by patching 0 at both ends, resulting in $n + 1$ positions between adjacent elements. These positions allow us to insert $n + 1$ into σ to generate $n + 1$ permutations in \mathfrak{S}_{n+1} . Let $\pi^{(i)}$ be permutation in \mathfrak{S}_{n+1} obtained by inserting the element $n + 1$ into σ at the position $n + 1 - i$, where $0 \leq i \leq n$. It is easy to check that

$$\text{inv}(\pi^{(i)}) = \text{inv}(\sigma) + i.$$

To prove (5.18), it is enough to show that

$$\begin{aligned} & q^{\text{inv}(\sigma)} \omega_1(\sigma) \cdots \omega_{i-1}(\sigma) R(\omega_i(\sigma)) \uparrow (\omega_{i+1}(\sigma) \cdots \omega_{n+1}(\sigma)) \\ &= q^{\text{inv}(\pi^{(i)})} \omega(\pi^{(i)}) = q^{\text{inv}(\sigma)+i} \omega_1(\pi^{(i)}) \omega_2(\pi^{(i)}) \cdots \omega_{n+2}(\pi^{(i)}). \end{aligned} \quad (5.19)$$

We consider two cases:

Case 1: Suppose $\omega_i(\sigma) = x_i$ (i.e., position $n + 1 - i$ in the grammatical labeling of σ is assigned the label x_i). For the labeling of $\pi^{(i)}$:

- Position $n + 1 - i$ is labeled x_{i+1} ;
- Position $n + 2 - i$ is labeled y_i ;
- All labels of $\pi^{(i)}$ at positions after $n + 2 - i$ are identical to those of σ ;
- Each label of $\pi^{(i)}$ at positions before $n + 1 - i$ has a subscript that is exactly one greater than the subscript of the corresponding label in σ .

$$\begin{aligned} \sigma &= 0 \quad x_n \quad \sigma_1 \cdots \sigma_{n-i} \quad x_i \quad \sigma_{n-i+1} \quad \cdots \quad \sigma_n \quad y_0 \quad 0 \\ \Rightarrow \pi^{(i)} &= 0 \quad x_{n+1} \quad \sigma_1 \cdots \sigma_{i-1} \quad x_{i+1} \quad n+1 \quad y_i \quad \sigma_{n-i+1} \quad \cdots \quad \sigma_n \quad y_0 \quad 0. \end{aligned}$$

Since $R(x_i) = q^i y_i x_{i+1}$, the relation (5.19) follows immediately.

Case 2: Suppose $\omega_i(\sigma) = y_i$ (i.e., position $n + 1 - i$ in the grammatical labeling of σ is assigned the label y_i). Then $\pi^{(i)}$ has x_{i+1} at position $n + 1 - i$, y_i at position $n + 2 - i$ in its labeling. As in Case 1, labels of $\pi^{(i)}$ for all positions after $n + 2 - i$ coincide with those of σ , and for each position before

$n + 1 - i$, the subscript of the label of $\pi^{(i)}$ is one greater than the subscript of the corresponding label of σ .

$$\begin{aligned} \sigma &= 0 \quad x_n \quad \sigma_1 \cdots \quad \sigma_{n-i} \quad y_i \quad \sigma_{n-i+1} \quad \cdots \quad \sigma_n \quad y_0 \quad 0 \\ \Rightarrow \pi^{(i)} &= 0 \quad x_{n+1} \quad \sigma_1 \cdots \quad \sigma_{i-1} \quad x_{i+1} \quad n+1 \quad y_i \quad \sigma_{n-i+1} \quad \cdots \quad \sigma_n \quad y_0 \quad 0 . \end{aligned}$$

Given $R(y_i) = q^i y_i x_{i+1}$, the relation (5.19) is likewise valid for this case, (5.18) follows at once.

Summing the results from these two cases shows that the assertion (5.19) holds, and thus (5.18) is valid for $n + 1$. Theorem 5.4 follows immediately from (5.18). This completes the proof. \square

5.3. q -Grammar calculus for q -inv-Eulerian polynomials. Based on the framework of q -grammar calculus developed in Section 4, this subsection uses Theorem 5.4 to derive a grammatical proof of Theorem 5.1.

Proposition 5.5. *Let G_{inv} be the q -grammar defined in Theorem 5.4, and let D be the q -derivative associated with G_{inv} . For $n \geq 1$ and $i \geq 0$,*

$$D^n(x_i^{-1}) = -q^{ni} x_i^{-1} y_i (x_{i+1} - y_{i+1})^{n-1}, \quad (5.20)$$

$$D^n(y_i^{-1}) = -q^{\binom{n}{2} + ni} \prod_{k=1}^{n-1} (y_{i+k} - x_{i+k}) x_{i+n} y_{i+n}^{-1}. \quad (5.21)$$

Proof. Observe that

$$D(x_i^{-1}) = -x_i^{-1} R(x_i) \uparrow (x_i^{-1}) = -q^i x_i^{-1} y_i x_{i+1} x_{i+1}^{-1} = -q^i x_i^{-1} y_i, \quad (5.22)$$

and

$$D(y_i^{-1}) = -y_i^{-1} R(y_i) \uparrow (y_i^{-1}) = -q^i y_i^{-1} y_i x_{i+1} y_{i+1}^{-1} = -q^i x_{i+1} y_{i+1}^{-1}, \quad (5.23)$$

Moreover,

$$\begin{aligned} D(x_i^{-1} y_i) &= \mathbf{AIO}(R(x_i^{-1}) y_{i+1} + x_i^{-1} R(y_i)) \\ &= -q^i x_i^{-1} y_i y_{i+1} + q^i x_i^{-1} y_i x_{i+1} \\ &= q^i x_i^{-1} y_i (x_{i+1} - y_{i+1}) \end{aligned}$$

and

$$\begin{aligned} D(x_{i+1} y_{i+1}^{-1}) &= \mathbf{AIO}(R(x_{i+1}) y_{i+2}^{-1} + x_{i+1} R(y_{i+1}^{-1})) \\ &= q^{i+1} y_{i+1} x_{i+2} y_{i+2}^{-1} - q^{i+1} x_{i+1} x_{i+2} y_{i+2}^{-1} \\ &= q^{i+1} (y_{i+1} - x_{i+1}) x_{i+2} y_{i+2}^{-1}. \end{aligned}$$

Since $D(x_i - y_i) = 0$ for all $i \geq 0$ in the q -grammar defined by (5.15), by induction, we derive that for $n \geq 0$,

$$D^n(x_i^{-1} y_i) = q^{ni} x_i^{-1} y_i (x_{i+1} - y_{i+1})^n, \quad (5.24)$$

$$D^n (x_{i+1}y_{i+1}^{-1}) = q^{ni+\binom{n+1}{2}} \prod_{k=1}^n (y_{i+k} - x_{i+k}) x_{i+n+1} y_{i+n+1}^{-1} \quad (5.25)$$

Combining these identities with (5.22) and (5.23) immediately establishes the identities (5.20) and (5.21), respectively. \square

Corollary 5.6. *Let G_{inv} be the q -grammar given in Theorem 5.4 with ϕ the corresponding evaluation map. Then for $i \geq 0$,*

$$\phi(\text{Gen}_q^{(G_{\text{inv}})}(x_i^{-1}; u)) = \frac{1 - x^{-1}y e_q((x - y)uq^i)}{x - y} \quad (5.26)$$

and

$$\phi(\text{Gen}_q^{(G_{\text{inv}})}(y_i^{-1}; u)) = \frac{1 - xy^{-1}E_q((y - x)uq^i)}{y - x}, \quad (5.27)$$

where $e_q(u)$ and $E_q(u)$ are as defined in (2.4) and (2.5), respectively.

Proof. Applying (5.20), we deduce that

$$\begin{aligned} \phi(\text{Gen}_q^{(G_{\text{inv}})}(x_i^{-1}; u)) &= \sum_{n=0}^{+\infty} \phi(D^n(x_i^{-1})) \frac{u^n}{(q; q)_n} \\ &= x^{-1} - \sum_{n=1}^{+\infty} x^{-1}y(x - y)^{n-1} q^{ni} \frac{u^n}{(q; q)_n} \\ &= x^{-1} - \frac{x^{-1}y}{x - y} (e_q((x - y)uq^i) - 1) \\ &= \frac{1 - x^{-1}y e_q((x - y)uq^i)}{x - y}. \end{aligned}$$

Similarly, using (5.20), we obtain

$$\begin{aligned} \phi(\text{Gen}_q^{(G_{\text{inv}})}(y_i^{-1}; u)) &= \sum_{n=0}^{+\infty} \phi(D^n(y_i^{-1})) \frac{u^n}{(q; q)_n} \\ &= y^{-1} - \sum_{n=1}^{+\infty} q^{\binom{n}{2}+ni} xy^{-1}(y - x)^{n-1} \frac{u^n}{(q; q)_n} \\ &= y^{-1} - \frac{xy^{-1}}{y - x} (E_q((y - x)uq^i) - 1) \\ &= \frac{1 - xy^{-1}E_q((y - x)uq^i)}{y - x}. \end{aligned}$$

\square

Theorem 5.7. *Let G_{inv} be the q -grammar defined in Theorem 5.4 and let ϕ be the evaluation map as defined therein. Then*

$$\phi(\text{Gen}_q^{(G_{\text{inv}})}(x_i; u)) = \frac{x - y}{1 - x^{-1}ye_q((x - y)uq^i)}. \quad (5.28)$$

Proof. It is straightforward to check that ϕ in Theorem 5.4 is a master-linear evaluation and the grammar G_{inv} defined in (5.15) satisfies (4.4). Consequently, by Theorem 4.14, we deduce that

$$1 = \phi(\text{Gen}_q^{(G_{\text{inv}})}(x_i x_i^{-1}; u)) = \phi(\text{Gen}_q^{(G_{\text{inv}})}(x_i; u))\phi(\text{Gen}_q^{(G_{\text{inv}})}(x_i^{-1}; u)).$$

Hence, applying Corollary 5.6, we arrive at (5.28). \square

By combining Theorem 5.4 and Theorem 5.7, we recover Theorem 5.1.

5.4. q -Grammar for cycle q -Roselle polynomials.

Theorem 5.8. *Let $G_{\text{cyc}} = (\{x, y, z, e\}, R, \mathbf{KSO})$ be the q -grammar, where*

$$R = \{x_j \rightarrow q^j y_j x_{j+1}, y_j \rightarrow q^j y_j x_{j+1}, z_j \rightarrow q^j y_j x_{j+1}, e_j \rightarrow \beta q^j e_j z_{j+1}\}.$$

Let D be the q -derivative associated with G_{cyc} and define the evaluation map ϕ by $\phi(x_j) = x$, $\phi(y_j) = y$, $\phi(z_j) = z$ and $\phi(e_j) = e$. Then

$$\phi(D^n(e_0)) = eF_n(q; x, y, z|\beta).$$

Proof. Let $\sigma = \sigma_1 \cdots \sigma_n \in \mathfrak{S}_n$. For $1 \leq i \leq n + 1$, recall that the position i is said to be the position immediately before σ_i , whereas the position $n + 1$ is meant to be the position after σ_n . We patch 0 to σ at both ends so that there are $n + 1$ positions between two adjacent elements. For $1 \leq i \leq n + 1$, we label the position i of $\sigma \in \mathfrak{S}_n$ as follows:

- If i is a descent, then label it by y_{n+1-i} ;
- If σ_i is an isolated element, then label i by z_{n+1-i} ;
- If i is a non-isolated ascent, then label it by x_{n+1-i} ;
- If $i = n + 1$, then label it by e_0 .

Below shows the grammatical labeling of a permutation $\sigma = 541273698 \in \mathfrak{S}_9$.

$$0 \quad y_9 5 \quad x_8 4 \quad x_7 1 \quad | \quad z_6 2 \quad | \quad y_5 7 \quad x_4 3 \quad | \quad z_3 6 \quad | \quad y_2 9 \quad x_1 8 \quad e_0 \quad 0$$

The weight ω of σ is defined to be the product of all these labels taken from right to left. For the example above, its weight is given by

$$\omega(\sigma) = e_0 x_1 y_2 z_3 x_4 y_5 z_6 x_7 x_8 y_9.$$

Note that

$$\phi \left(\sum_{\sigma \in \mathfrak{S}_n} q^{\text{inv}(\sigma)} \beta^{\text{RLmin}(\sigma)} \omega(\sigma) \right) = eF_n^{\text{inv}}(q; x, y, z|\beta),$$

and consequently, Theorem 5.8 follows immediately upon verifying the following assertion: For $n \geq 1$,

$$D^n(e_0) = \sum_{\sigma \in \mathfrak{S}_n} q^{\text{inv}(\sigma)} \beta^{\text{RLmin}(\sigma)} \omega(\sigma). \quad (5.29)$$

We proceed by induction on n . For $n = 1$, the statement is evident. Assume that (5.29) holds for n . To demonstrate that it also holds for $n + 1$, it suffices to show, by (5.29), that

$$D \left(\sum_{\sigma \in \mathfrak{S}_n} q^{\text{inv}(\sigma)} \beta^{\text{RLmin}(\sigma)} \omega(\sigma) \right) = \sum_{\pi \in \mathfrak{S}_{n+1}} q^{\text{inv}(\pi)} \beta^{\text{RLmin}(\pi)} \omega(\pi). \quad (5.30)$$

For a permutation $\sigma \in \mathfrak{S}_n$, we define the weight

$$\omega(\sigma) = \omega_1(\sigma) \omega_2(\sigma) \cdots \omega_{n+1}(\sigma)$$

the product of the right-to-left labels in the grammatical labeling of σ .

Similarly, for the permutation $\pi \in \mathfrak{S}_{n+1}$, the weight is given by

$$\omega(\pi) = \omega_1(\pi) \omega_2(\pi) \cdots \omega_{n+2}(\pi)$$

the product of the right-to-left labels in the grammatical labeling of π .

By the q -product formula and note that ρ is KSO (Keep Sequence Order), we have

$$D(\omega(\sigma)) = \sum_{i=1}^{n+1} \omega_1(\sigma) \cdots \omega_{i-1}(\sigma) R(\omega_i(\sigma)) \uparrow (\omega_{i+1}(\sigma) \cdots \omega_{n+1}(\sigma)).$$

Next, we represent a permutation $\sigma = \sigma_1 \cdots \sigma_n$ in \mathfrak{S}_n by patching 0 at both ends, resulting in $n + 1$ positions between adjacent elements. These positions allow us to insert $n + 1$ into σ to generate $n + 1$ permutations in \mathfrak{S}_{n+1} . Let $\pi^{(i)}$ be permutation in \mathfrak{S}_{n+1} obtained by inserting the element $n + 1$ into σ at the position $n + 1 - i$, where $0 \leq i \leq n$. To prove (5.30), it is enough to show that

$$\begin{aligned} & \beta^{\text{RLmin}(\sigma)} q^{\text{inv}(\sigma)} \omega_1(\sigma) \cdots \omega_{i-1}(\sigma) R(\omega_i(\sigma)) \uparrow (\omega_{i+1}(\sigma) \cdots \omega_{n+1}(\sigma)) \\ &= \beta^{\text{RLmin}(\pi^{(i)})} q^{\text{inv}(\pi^{(i)})} \omega_1(\pi^{(i)}) \omega_2(\pi^{(i)}) \cdots \omega_{n+2}(\pi^{(i)}). \end{aligned} \quad (5.31)$$

We consider the following four cases:

Case 1: Suppose $\omega_i(\sigma) = x_i$ (i.e., position $n + 1 - i$ in the grammatical labeling of σ is assigned the label x_i). Then in the labeling of $\pi^{(i)}$, position $n + 1 - i$ is labeled x_{i+1} and position $n + 2 - i$ is labeled y_i ; labels of $\pi^{(i)}$ after position $n + 2 - i$ coincide with those of σ , and each label of $\pi^{(i)}$ before position $n + 1 - i$ has a subscript one greater than the corresponding subscript in the labeling of σ . Furthermore,

$$\text{RLmin}(\pi^{(i)}) = \text{RLmin}(\sigma) \quad \text{and} \quad \text{inv}(\pi^{(i)}) = \text{inv}(\sigma) + i. \quad (5.32)$$

Since $R(x_i) = q^i y_i x_{i+1}$, relation (5.31) follows immediately.

Case 2: Suppose $\omega_i(\sigma) = y_i$ (i.e., position $n + 1 - i$ in σ 's grammatical labeling is y_i). Then $\pi^{(i)}$ has x_{i+1} at position $n + 1 - i$, y_i at position $n + 2 - i$ in its labeling. As in Case 1, labels of $\pi^{(i)}$ for all positions after $n + 2 - i$ coincide with those of σ , and for each position before $n + 1 - i$, the subscript of the label of $\pi^{(i)}$ is one greater than the subscript of the corresponding label of σ . Given $R(y_i) = q^i y_i x_{i+1}$ and relation (5.32) is likewise valid for this case, (5.31) follows at once.

Case 3: If $\omega_i(\sigma) = z_i$ (position $n + 1 - i$ in σ 's grammatical labeling is z_i), the labeling of $\pi^{(i)}$ satisfies x_{i+1} at $n + 1 - i$, y_i at $n + 2 - i$, labels coincide with σ for position $> n + 2 - i$, and a subscript increment of 1 for labels at position $< n + 1 - i$ (as in Case 1). Since $R(z_i) = q^i y_i x_{i+1}$ and (5.32) also valid here, (5.31) is an immediate consequence.

Case 4: If position $n + 1 - i$ in the labeling of σ is assigned e_0 , then $i = 0$ and $\omega_1(\sigma) = e_0$. In the labeling of $\pi^{(n+1)}$, position $n + 1$ is labeled z_1 and position $n + 2$ is labeled e_0 ; for every position preceding $n + 1$, the subscript of the label of $\pi^{(0)}$ is one greater than the subscript of the corresponding label of σ . We have $\text{RLmin}(\pi^{(0)}) = \text{RLmin}(\sigma) + 1$ and $\text{inv}(\pi^{(0)}) = \text{inv}(\sigma)$. Together with $R(e_0) = \beta e_0 z_1$, relation (5.31) follows.

Summing the four cases proves (5.31), so (5.29) holds for $n + 1$, and Theorem 5.8 follows accordingly. \square

5.5. q -Grammar calculus for cycle q -Roselle polynomials. This subsection is devoted to providing a grammatical proof of Theorem 5.2. By Theorem 5.8, it suffices to establish the following consequence.

Theorem 5.9. *Let G_{cyc} be the q -grammar defined in Theorem 5.8 and let ϕ be the evaluation map as defined therein. Then*

$$\phi(\text{Gen}_q^{(G_{\text{cyc}})}(e_0; u)) = e \prod_{k=0}^{+\infty} \frac{1}{1 - \beta u q^k \phi(\text{Gen}_q(z_1; u q^k))},$$

where

$$\phi(\text{Gen}_q^{(G_{\text{cyc}})}(z_1; u q^k)) = \frac{z - y + x^{-1} y (x - z) e_q((x - y) u q^{k+1})}{1 - x^{-1} y e_q((x - y) u q^{k+1})}. \quad (5.33)$$

Proof. Using Proposition 4.9, we have

$$D_q \text{Gen}_q^{(G_{\text{cyc}})}(e_0; u) = \text{Gen}_q^{(G_{\text{cyc}})}(D(e_0); u)$$

By definition, we observe that

$$\text{Gen}_q^{(G_{\text{cyc}})}(D(e_0); u) = \text{Gen}_q^{(G_{\text{cyc}})}(\beta e_0 z_1; u) = \beta \text{Gen}_q^{(G_{\text{cyc}})}(e_0 z_1; u)$$

and

$$D_q \text{Gen}_q^{(G_{\text{cyc}})}(e_0; u) = \frac{\text{Gen}_q^{(G_{\text{cyc}})}(e_0; u) - \text{Gen}_q^{(G_{\text{cyc}})}(e_0; u q)}{u}$$

Therefore,

$$\text{Gen}_q^{(G_{\text{cyc}})}(e_0; u) - \text{Gen}_q^{(G_{\text{cyc}})}(e_0; uq) = \beta u \text{Gen}_q^{(G_{\text{cyc}})}(e_0 z_1; u).$$

Applying the evaluation map ϕ to both sides, we obtain

$$\phi(\text{Gen}_q^{(G_{\text{cyc}})}(e_0; u)) - \phi(\text{Gen}_q^{(G_{\text{cyc}})}(e_0; uq)) = \beta u \phi(\text{Gen}_q^{(G_{\text{cyc}})}(e_0 z_1; u)). \quad (5.34)$$

Note that ϕ in Theorem 5.8 is a master-linear evaluation and the grammar G_{cyc} defined in Theorem 5.8 satisfies condition (4.4). By Theorem 4.14, we obtain the multiplicative identity:

$$\phi(\text{Gen}_q^{(G_{\text{cyc}})}(e_0 z_1; u)) = \phi(\text{Gen}_q^{(G_{\text{cyc}})}(e_0; u)) \phi(\text{Gen}_q^{(G_{\text{cyc}})}(z_1; u)). \quad (5.35)$$

Substituting (5.35) into (5.34) yields

$$\begin{aligned} \phi(\text{Gen}_q^{(G_{\text{cyc}})}(e_0; u)) &= \phi(\text{Gen}_q^{(G_{\text{cyc}})}(e_0; uq)) \cdot \frac{1}{1 - \beta u \phi(\text{Gen}_q^{(G_{\text{cyc}})}(z_1; u))} \\ &= e \prod_{k=0}^{+\infty} \frac{1}{1 - \beta u q^k \phi(\text{Gen}_q^{(G_{\text{cyc}})}(z_1; u q^k))}. \end{aligned}$$

From Theorem 5.7, we have

$$\begin{aligned} \phi(\text{Gen}_q^{(G_{\text{cyc}})}(z_1; u q^k)) &= \phi(\text{Gen}_q^{(G_{\text{inv}})}(x_1; u q^k)) - x + z \\ &= \frac{x - y}{1 - x^{-1} y e_q((x - y) u q^{k+1})} - x + z \\ &= \frac{z - y + x^{-1} y (x - z) e_q((x - y) u q^{k+1})}{1 - x^{-1} y e_q((x - y) u q^{k+1})}. \quad (5.36) \end{aligned}$$

This completes the proof. \square

6. q -GRAMMAR FOR ANDRÉ PERMUTATIONS AND THEIR GENERALIZATIONS

This section aims to provide q -analogues of the grammar established by Dumont [19] for André polynomials. Recall that the André polynomials are defined in terms of 0-1-2 increasing trees. An increasing tree on $[n] := \{1, 2, \dots, n\}$ is a rooted tree with vertex set $[n]$ in which the labels of the vertices are increasing along any path from the root. Note that 1 is the root. A 0-1-2 increasing tree is an increasing tree in which the degree of any vertex is at most two. The degree of a vertex in a rooted tree is meant to be the number of its children. Given a 0-1-2 increasing tree T , let $l(T)$ denote the number of leaves of T , and let $u(T)$ denote the number of vertices of T with degree 1. The André polynomial $E_n(x, y)$ is defined by

$$E_n(x, y) = \sum_T x^{l(T)} y^{u(T)},$$

where the sum ranges over 0-1-2 increasing trees on $[n]$.

Setting $x = y = 1$, $E_n(x, y)$ reduces to the n -th Euler number E_n , which counts 0-1-2 increasing trees on $[n]$ as well as alternating permutations on $[n]$ and André permutations on $[n]$, see [26, 43, 58].

Dumont [19] found the grammar (I.14) to generate the André polynomials $E_n(x, y)$ and Chen and Fu [6] provided a grammatical derivation of the generating function formula for $E_n(x, y)$, see Appendix I for details.

In this section, we aim to provide q -analogues of the grammar (I.14). It is natural to define q -André polynomials via André permutations, incorporating statistics for descents and inversions.

André permutations were first introduced by Foata and Schützenberger and further studied by Strehl [60] and Foata and Strehl [27, 28]. For clarity, we will work with permutations of length n for which each permutation is a sequence of n distinct integers not necessarily from 1 to n . The empty word e and any single-letter word are defined as both *André I permutations* and *André II permutations*. For a permutation $\sigma = \sigma_1\sigma_2\cdots\sigma_n$ ($n \geq 2$) of length n , we decompose it as $\sigma = \tau \min(\sigma) \tau'$. Here σ is the concatenation of a left factor τ , followed by the minimum letter $\min(\sigma)$, and a right factor τ' . Then, σ is called an *André I permutation* (resp. *André II permutation*) if both τ and τ' are André I permutations (resp. André II permutations), and the maximum letter of the subword $\tau\tau'$ lies in τ' (resp. the minimum letter of $\tau\tau'$ lies in τ').

We denote by And_n^I the set of all André I permutations of $[n] := \{1, 2, \dots, n\}$, and by And_n^{II} the set of all André II permutations of $[n]$. This inductive definition immediately establishes a connection to the Euler numbers, as it can be shown that the number of André I permutations and André II permutations on the set $[n]$ are equal, i.e., $E_n = |\text{And}_n^I| = |\text{And}_n^{II}|$.

André I permutations for $n \leq 5$ are listed below:

$n = 1$: 1; $n = 2$: 12; $n = 3$: 123, 213;
 $n = 4$: 1234, 1324, 2314, 2134, 3124;
 $n = 5$: 12345, 12435, 13425, 23415, 13245, 14235, 34125, 24135,
 23145, 21345, 41235, 31245, 21435, 32415, 41325, 31425.

André II permutations for $n \leq 5$ are listed below:

$n = 1$: 1; $n = 2$: 12; $n = 3$: 123, 312;
 $n = 4$: 1234, 1423, 3412, 4123, 3124;
 $n = 5$: 12345, 12534, 14523, 34512, 15234, 14235, 34125, 45123,
 35124, 51234, 41235, 31245, 51423, 53412, 41523, 31524.

We introduce the following polynomials defined on André permutations, which incorporate statistics for descents and inversions.

$$F_n^I(q; t) = \sum_{\sigma \in \text{And}_n^I} t^{\text{des}(\sigma)} q^{\text{inv}(\sigma)}, \quad (6.1)$$

$$F_n^{II}(q; t) = \sum_{\sigma \in \text{And}_n^{II}} t^{\text{des}(\sigma)} q^{\text{inv}(\sigma)}, \quad (6.2)$$

where $\text{inv}(\sigma)$ counts the number of inversions of σ and $\text{des}(\sigma)$ counts the number of descents of σ ; see the beginning of Section 5 for their definitions.

We have

$$\begin{aligned} F_1^I(q; t) &= F_2^I(q; t) = t \\ F_3^I(q; t) &= t + qt^2 \\ F_4^I(q; t) &= t + (2q + 2q^2)t^2 \\ F_5^I(q; t) &= t + (3q + 4q^2 + 3q^3 + q^4)t^2 + (q^2 + q^3 + 2q^4)t^3 \end{aligned}$$

and

$$\begin{aligned} F_1^{II}(q; t) &= F_2^{II}(q; t) = t \\ F_3^{II}(q; t) &= t + q^2t^2 \\ F_4^{II}(q; t) &= t + (2q^2 + q^3 + q^4)t^2 \\ F_5^{II}(q; t) &= t + (2q^6 + q^5 + 3q^4 + 2q^3 + 3q^2)t^2 + (q^8 + q^6 + q^5 + q^4)t^3 \end{aligned}$$

It is well known that there exists a bijection Ψ between the set of permutations on $[n]$ and the set of increasing binary trees on $[n]$, see [59, Chapter 1]. Recall that an increasing binary tree is an increasing tree in which each vertex has at most two children, and the two children are distinguished as left and right (i.e., the tree is ordered).

Definition 6.1 (The map Ψ). Let $\pi = \pi_1\pi_2 \cdots \pi_n$ be a sequence of n distinct letters not necessarily from 1 to n . Define a binary tree T as follows. If $\pi = \emptyset$, then $T = \emptyset$. If $\pi \neq \emptyset$, then let i be the least letter of π . Thus π can be factored uniquely in the form $\pi = \sigma i \tau$. Now let i be the root of T , and let T and T_τ be the left and right subtrees obtained by removing i (see Figure 1). This yields an inductive definition of T .

As noted by Stanley [59, Chapter 1], numerous permutation statistics, such as descents, double descents, peaks, and valleys, correspond to statistics on increasing binary trees under the bijection Ψ . We find that the inversion number of permutations corresponds to the following inversion statistic defined on increasing binary trees under the bijection Ψ . It should

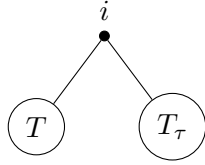
FIGURE 1. An inductive definition of T

be pointed out that this inversion statistic on increasing binary trees is different from the notion of inversion in rooted labeled trees (see, e.g., Mallows and Riordan [49] and Gessel [33]).

Definition 6.2. Let T be an increasing binary trees on the set $[n]$. An inversion in T is a pair of vertices (i, j) where $i > j$, and either:

- (1) j lies to the right of the path from the root (labeled 1) to i , or
- (2) j is on the path from the root (labeled 1) to i , and the left child of j is contained in this path.

Let $\text{inv}_i(T)$ denote the number of vertices j of T such that (i, j) is an inversion of T , and the inversion number of T is defined by

$$\text{inv}(T) = \sum_{i=1}^n \text{inv}_i(T). \quad (6.3)$$

For example, the tree T_1 given in Figure 2 has two inversions: $(2, 1)$ and $(3, 1)$, so $\text{inv}(T_1) = 2$. In contrast, the tree T_2 given in Figure 2 has four inversions: $(3, 1)$, $(3, 2)$, $(4, 1)$, and $(4, 2)$, so $\text{inv}(T_2) = 4$.

Applying the bijection Ψ to the trees T_1 and T_2 in Figure 2, we obtain

$$\Psi(T_1) = 2314 \quad \text{and} \quad \Psi(T_2) = 3412.$$

It is straightforward to verify that $\text{inv}(2314) = 2$ and $\text{inv}(3412) = 4$, which is consistent with the tree inversion statistics.

As observed by Foata and the first author [22], when restricted to André permutations, the bijection Ψ induces a bijection sending André permutations to special cases of increasing binary trees, which we refer to as André trees.

Definition 6.3. An André I tree is an increasing binary tree satisfying the maxima of the sibling subtrees are in increasing order (by convention, maximum of empty tree is 0), whereas, an André II tree is an increasing binary tree satisfying the minima of k sibling subtrees are in decreasing order (by convention, minimum of empty tree is $+\infty$).

The sets of André I trees on $[n]$ and André II trees on $[n]$ are denoted by \mathcal{T}_n^I and \mathcal{T}_n^{II} , respectively.

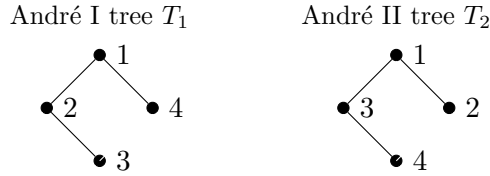

FIGURE 2. Two André trees on $[4]$

It is easy to see that André I trees can be derived from 0-1-2-increasing trees by requiring the maxima of the two sibling subtrees to be in increasing order, whereas André II trees can be derived from 0-1-2-increasing trees by requiring the minima of the two sibling subtrees to be in decreasing order. With the conventions that the maximum of an empty tree is 0 and the minimum of an empty tree is $+\infty$. It follows that

$$E_n = |\mathcal{T}_n^I| = |\mathcal{T}_n^{II}|.$$

Using the bijection Ψ , it is straightforward to verify that André I trees on $[n]$ are in bijection with André I permutations on $[n]$, and André II trees on $[n]$ are in bijection with André II permutations on $[n]$. Moreover, the descent number of an André permutation is determined by the number of leaves of the corresponding André tree.

Proposition 6.4. *The bijection Ψ defined in Definition 6.1 is a bijection between the set \mathcal{T}_n^I of André I trees on $[n]$ (resp. the set \mathcal{T}_n^{II} of André II trees on $[n]$) and the set And_n^I of André I permutations on $[n]$ (resp. the set And_n^{II} of André II permutations on $[n]$). Moreover, for any $T \in \mathcal{T}_n^I$ (resp. $T \in \mathcal{T}_n^{II}$), if $\pi = \Psi(T)$, then*

$$l(T) = \text{des}(\pi) \quad \text{and} \quad \text{inv}(T) = \text{inv}(\pi).$$

Using Proposition 6.4, we are now able to express the polynomials $F_n^I(q; t)$ and $F_n^{II}(q; t)$ in terms of André tree, which we refer to q -André polynomials.

$$E_n^I(q; x, y) = \sum_{\sigma \in \mathcal{T}_n^I} x^{l(T)} y^{u(T)} q^{\text{inv}(T)}, \tag{6.4}$$

$$E_n^{II}(q; x, y) = \sum_{\sigma \in \mathcal{T}_n^{II}} x^{l(T)} y^{u(T)} q^{\text{inv}(T)}, \tag{6.5}$$

where $l(T)$, $u(T)$ and $\text{inv}(T)$ denote the number of leaves, the number of vertices of degree 1, and the inversion number of T , respectively.

From Proposition 6.4, we see that upon setting $y = 1$ and $x = t$, the polynomials $E_n^I(q; x, y)$ and $E_n^{II}(q; x, y)$ reduce to $F_n^I(q; t)$ and $F_n^{II}(q; t)$ respectively.

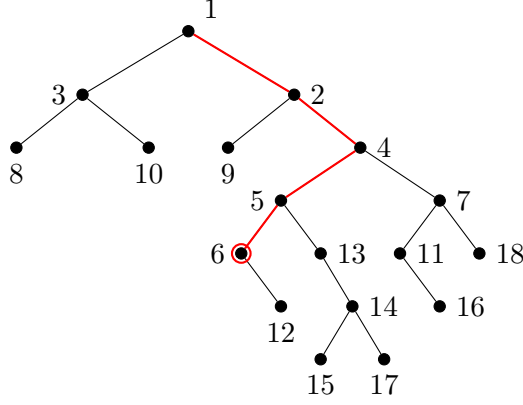
FIGURE 3. An André I trees T on $[18]$.

The remainder of this section is structured as follows. Subsection 6.1 presents the q -grammar for the q -André I polynomials (6.4) (see Theorem 6.5); Subsection 6.2 is devoted to the q -grammar for the q -André II polynomials (6.5) (see Theorem 6.12). We remark that this construction extends naturally to yield the q -grammar for q -analogues of k -André trees. These q -analogues are obtained by generalizing the inversion statistic from increasing binary trees to the setting of increasing k -ary trees.

6.1. q -Grammar for q -André I polynomials.

Theorem 6.5. *Let G_{AndI} be the q -grammar defined by*

$$G_{\text{AndI}} = (\{x, y\}, \{x_j \rightarrow q^j x_j y_{j+1}, y_j \rightarrow q^j x_j\}, \mathbf{AIO}). \quad (6.6)$$

Let D be the q -derivative associated with G_{AndI} and define the evaluation map ϕ by $\phi(x_j) = x$ and $\phi(y_j) = y$. Then

$$\phi(D^n(x_0)) = E_{n+1}^I(q; x, y). \quad (6.7)$$

We are ready to prove Theorem 6.5 by using the grammatical labeling. To do so, we first introduce several statistics on André I trees.

For $T \in \mathcal{T}_n^I$ and $v \in T$, let L_v be the set of vertices on the path from the root 1 to v , say $L_v = \{v_0 := 1 < v_1 < \dots < v_{m-1} < v_m := v\}$. Let N_v denote the set of vertices in L_v whose right child is not contained in L_v . For $v_i \in N_v$, let $T_{v_i}^r$ denote the subtree rooted at the right child of v_i and let $n_r(v_i)$ be the number of vertices in $T_{v_i}^r$ with convention that $n_r(v_i) = 0$ if $T_{v_i}^r = \emptyset$. We define the following statistic for $v \in T$:

$$\Delta_I^T(v) = \sum_{v_i \in N_v} n_r(v_i).$$

When the context of the tree T is clear, we simplify the notation to $\Delta_I(v)$.

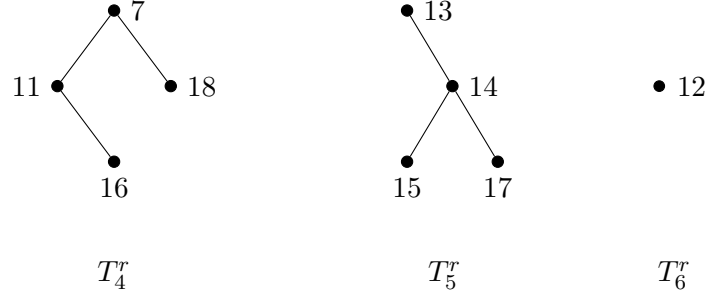

FIGURE 4. Subtrees rooted at the right children of 4, 5, 6.

From Fig. 3, we see that $L_6 = \{1, 2, 4, 5, 6\}$, where $T_1^r = T_2^r = \emptyset$ and T_4^r, T_5^r and T_6^r are given in Fig. 4. Hence,

$$N_v = \{4, 5, 6\} \quad \text{and} \quad \Delta_I(6) = n_r(4) + n_r(5) + n_r(6) = 9.$$

From the definition of Δ_I , it is not difficult to show that

Proposition 6.6. *Let T be an André I tree in \mathcal{T}_n^I and let u, v be two vertices in T each having at most one child. If u lies on or to the left of the path from the root 1 to v , then $\Delta_I(u) > \Delta_I(v)$; otherwise $\Delta_I(u) < \Delta_I(v)$.*

An insertion algorithm for André I trees: Let T be an André I tree. Suppose T has m vertices with at most one child. We present an insertion algorithm to generate m André I trees on $[n + 1]$ by inserting $n + 1$ into T .

Let v be the leaf or the vertex with exactly one child in T . We define ϕ_v that transform T into an André I tree on $[n + 1]$ via operations on v .

Recall that L_v denotes the set of vertices on the path from the root 1 to v :

$$L_v = \{v_0 := 1 < v_1 < \dots < v_j := v\}$$

Let v_1^r, \dots, v_k^r be the k vertices in L_v whose right children are not in L_v , that is,

$$N_v = \{v_1^r, \dots, v_k^r\}.$$

Denote by $T_{v_i^r}^r$ the subtree rooted at the right child of v_i^r and let a_i be largest vertex in the subtree $T_{v_i^r}^r$. Define

$$M(L_v) := \{a_1 > a_2 > \dots > a_k\}.$$

Relabel the elements of $M(L_v)$ according to the permutation

$$\begin{pmatrix} a_1 & a_2 & a_3 & \dots & a_k \\ n + 1 & a_1 & a_2 & \dots & a_{k-1} \end{pmatrix}$$

If v is a leaf of T , then assign a_k as the right child of v (see Fig. 5); If v has one child of T , then assign a_k as the left child of v (see Fig. 6). This

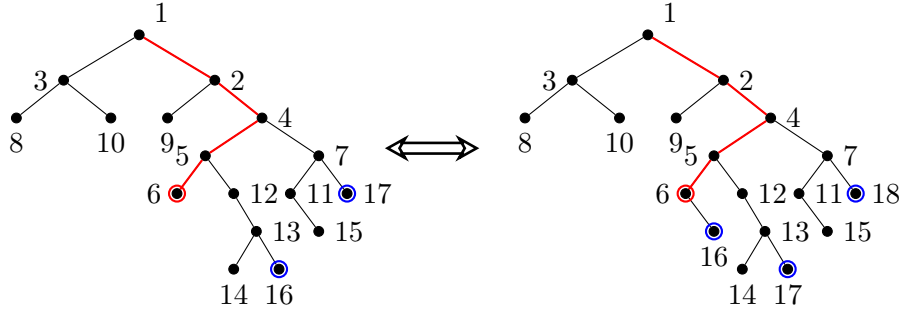
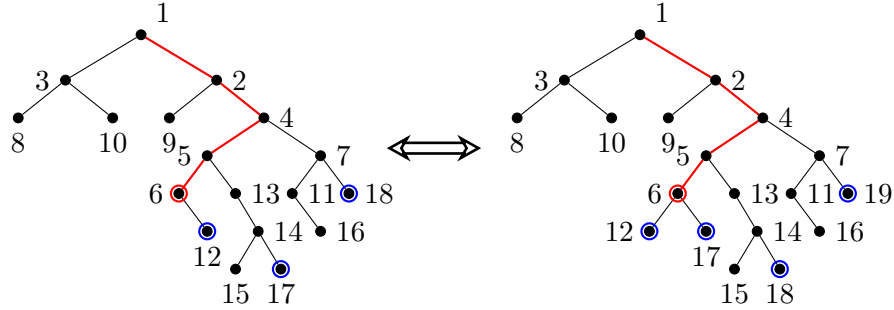
FIGURE 5. The bijection ϕ_6 , where $M(L_6) = \{17, 16\}$.FIGURE 6. The bijection ϕ_6 , where $M(L_6) = \{18, 17, 12\}$.

yields an André I tree $\tilde{T} := \phi_v^I(T)$. It can be readily seen that the insertion algorithm is reversible.

From the construction of the insertion algorithm, it is not difficult to show the following proposition.

Proposition 6.7. *Let T be an André I tree on $[n]$ and let v be a vertex in T with at most one child. Suppose that $\tilde{T} = \phi_v(T)$. Then*

$$\text{inv}(\tilde{T}) - \text{inv}(T) = \Delta_I^T(v). \quad (6.8)$$

Moreover, for any vertex u in T with at most one child,

- (a) If u lies on or to the left of the path from root 1 to v , then

$$\Delta_{\tilde{T}}^I(u) = \Delta_I^T(u) + 1,$$

- (b) If u lies to the right of the path from root 1 to v and $u \notin M(L_v)$, then

$$\Delta_{\tilde{T}}^I(u) = \Delta_I^T(u),$$

- (c) If $u \in M(L_v) := \{a_1 > a_2 > \dots > a_k\}$, then

$$\Delta_{\tilde{T}}^I(a_k) = \Delta_I^T(v), \quad \Delta_{\tilde{T}}^I(n+1) = \Delta_I^T(a_1) = 0,$$

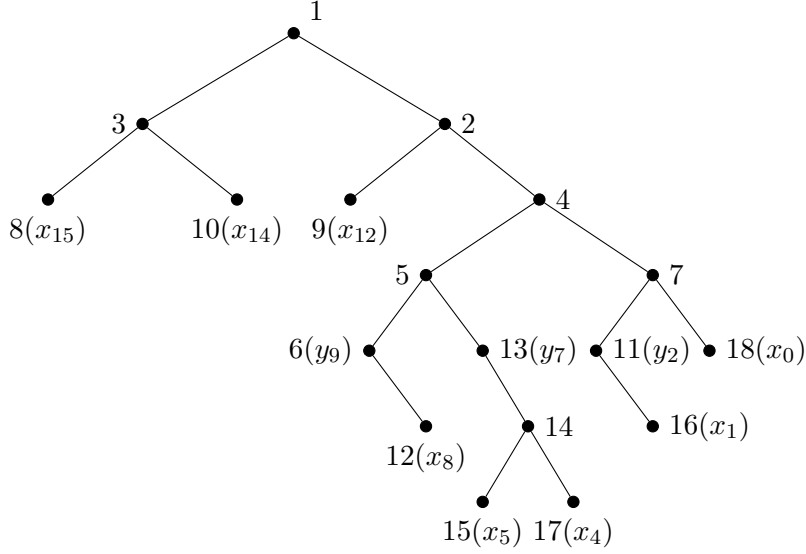

FIGURE 7. The labeling of an André I trees T on [18].

and for $1 \leq i \leq k - 1$,

$$\Delta_{\tilde{I}}^T(a_i) = \Delta_I^T(a_{i+1}),$$

(d) If v is a leaf of T , then

$$\Delta_{\tilde{I}}^T(v) = \Delta_I^T(v) + 1.$$

We are ready to prove Theorem 6.5 by using the grammatical labeling.

Let T be the André I trees on $[n]$. For $1 \leq i \leq n$, we label the vertex i in T as follows:

- If i is a leaf and $\Delta_I(i) = k$, then label it by x_k ;
- If i has only one child and $\Delta_I(i) = k$, then label it by y_k ;
- If i has two children, then it is left unlabeled.

The weight ω of $T \in \mathcal{T}_n^I$ is defined to be the product of all labels of T arranged in **AIO** order (that is, $x_0, y_0, x_1, y_1, \dots$).

For example, Fig. 7 shows the grammatical labeling of the André I trees T on [18]. We see that the weight of T is

$$\omega(T) = x_0x_1y_2x_4x_5y_7x_8y_9x_{12}x_{14}x_{15}.$$

To prove Theorem 6.5, we aim to show that the following assertion: For $n \geq 0$,

$$D^n(x_0) = \sum_{T \in \mathcal{T}_n^I} q^{\text{inv}(T)} \omega(T), \tag{6.9}$$

where D is q -derivative associated with q -grammar (6.6).

Proof of Theorem 6.5. We proceed by induction on n . For $n = 0$, the statement is evident. Assume that this statement holds for n , that is, the relation (6.9) is valid for $n - 1$. To demonstrate that it also holds for n , it suffices to show, by (6.9), that

$$D \left(\sum_{T \in \mathcal{T}_n^I} q^{\text{inv}(T)} \omega(T) \right) = \sum_{\tilde{T} \in \mathcal{T}_{n+1}^I} q^{\text{inv}(\tilde{T})} \omega(\tilde{T}). \quad (6.10)$$

Suppose T contains m vertices with at most one child and the weight of T is given by

$$\omega(T) = \omega_1(T) \omega_2(T) \cdots \omega_m(T).$$

By the q -product formula, we have

$$D(\omega(T)) = \sum_{i=1}^m \mathbf{AIO} \left(\omega_1(T) \cdots \omega_{i-1}(T) R(\omega_i(T)) \uparrow (\omega_{i+1}(T) \cdots \omega_m(T)) \right). \quad (6.11)$$

Let v_i be the vertex labeled by $\omega_i(T)$ in T , and let $\tilde{T}^{(i)} = \phi_{v_i}(T)$. To prove (6.10), it is enough to show that

$$\begin{aligned} & q^{\text{inv}(T)} \mathbf{AIO} \left(\omega_1(T) \cdots \omega_{i-1}(T) R(\omega_i(T)) \uparrow (\omega_{i+1}(T) \cdots \omega_m(T)) \right) \\ &= q^{\text{inv}(\tilde{T}^{(i)})} \omega(\tilde{T}^{(i)}). \end{aligned} \quad (6.12)$$

Since the letters of $\omega(T)$ are ordered as $x_0, y_0, x_1, y_1, \dots$, by Proposition 6.6, vertices labeled $\omega_1(T), \dots, \omega_{i-1}(T)$ lie to the right of the path from 1 to v_i in T , while the vertices labeled $\omega_{i+1}(T), \dots, \omega_m(T)$ lie either on this path or to its left. We consider two cases:

- Case 1: If $\omega_i(T) = x_k$, then v_i is a leaf of T with $\Delta_I(v_i) = k$. By Proposition 6.7, we see that (6.12) holds since $D(x_k) = q^k x_k y_{k+1}$.
- Case 2: If $\omega_i(T) = y_k$, then v_i is a vertex of T with exactly one child and $\Delta_I(v_i) = k$. In light of Proposition 6.7, we find that (6.12) is satisfied since $D(y_k) = q^k x_k$.

Summing the results from these two cases shows that the assertion (6.10) holds, and thus (6.9) is valid for $n + 1$. This completes the proof of Theorem 6.5. \square

Next, we will provide a grammatical derivation of the following identity for $E_{n+1}^I(q; x, y)$, which specializes to the relation for $E(x, y)$ established by Chen and Fu [6].

Theorem 6.8. *Set $E_0^I(q; x, y) = x$. For $n \geq 1$,*

$$E_{n+1}^I(q; x, y)$$

$$= yE_n^I(q; x, y) + \sum_{k=0}^{n-2} q^{n-k-1} \begin{bmatrix} n-1 \\ k \end{bmatrix}_q E_{k+1}^I(q; x, y) E_{n-k-1}^I(q; x, y). \quad (6.13)$$

Proof. Observe that the map ϕ from Theorem 6.5 is a master-linear evaluation, and the grammar G_{AndI} defined in (6.6) satisfies condition (4.4). In fact, from the proof of Theorem 6.5, the order **AIO** in the grammar G_{AndI} is equivalent to the order **KSO**. This implies that G_{AndI} is q -linear grammar.

Applying Theorem 4.14, we immediately obtain the following multiplicative identity:

$$\phi(\text{Gen}^{(G_{\text{AndI}})}(x_0 y_1; u)) = \phi(\text{Gen}^{(G_{\text{AndI}})}(x_0; u)) \phi(\text{Gen}^{(G_{\text{AndI}})}(y_1; u)).$$

This implies

$$\phi(D^n(x_0 y_1)) = \sum_{k=0}^n \begin{bmatrix} n \\ k \end{bmatrix}_q \phi(D^k(x_0)) \phi(D^{n-k}(y_1)), \quad (6.14)$$

where D is the q -derivative associated to the grammar G_{AndI} .

By Theorem 6.5, for all integers $k \geq 0$, we have

$$\phi(D^k(x_0)) = E_{k+1}^I(q; x, y). \quad (6.15)$$

Since the grammar G_{AndI} is q -linear, by Proposition 4.6, we derive that for $k \geq 1$,

$$\begin{aligned} \phi(D^k(y_1)) &= \phi(D^{k-1}(q x_1)) \\ &= q \phi(D^{k-1}(\uparrow x_0)) \\ &= q^k \phi(\uparrow D^{k-1}(x_0)) \\ &= q^k E_k^I(q; x, y). \end{aligned} \quad (6.16)$$

Substituting (6.15) and (6.16) into (6.14) yields

$$\begin{aligned} \phi(D^n(x_0 y_1)) &= y E_{n+1}^I(q; x, y) \\ &\quad + \sum_{k=0}^{n-1} q^{n-k} \begin{bmatrix} n \\ k \end{bmatrix}_q E_{k+1}^I(q; x, y) E_{n-k}^I(q; x, y). \end{aligned} \quad (6.17)$$

On the other hand, another application of Theorem 6.5 shows that for $n \geq 1$,

$$\phi(D^n(x_0)) = \phi(D^{n-1}(x_0 y_1)) = E_{n+1}^I(q; x, y). \quad (6.18)$$

Combining relations (6.17) and (6.18), we finally establish the recurrence (6.13). This completes the proof. \square

Finally, we remark that the q -grammar G_{AndI} defined in (6.6) contains several well-known integer sequences, as stated next.

Let D be the q -derivative associated with G_{AndI} given by (6.6) and define

$$D^n(x_0) = \sum_{w \in F(\mathbb{S})} a_w w. \quad (6.19)$$

It is easy to see that the word w in (6.19) is strictly characterized by a set of indices $\mathcal{I} \subseteq \{1, 2, \dots, n\}$ such that:

$$w = x_0 \prod_{i \in \mathcal{I}} v_i, \quad (6.20)$$

where the products are taken in increasing order of indices and $v_i = x_i$ or y_i . For a given word w in (6.20), we define a step sequence $S = (s_1, s_2, \dots, s_n)$ of length n as follows:

- $s_i = U$ (Up step, $(1, 1)$) if $i \in \mathcal{I}$ and $v_i = x_i$;
- $s_i = L$ (Level step, $(1, 0)$) if $i \in \mathcal{I}$ and $v_i = y_i$;
- $s_i = D^*$ (Down step, $(1, -1)$) if $i \notin \mathcal{I}$.

Proposition 6.9. *A word w is a term in (6.19) if and only if its associated step sequence S is a Motzkin path of length n (i.e., the path stays non-negative and ends at height 0). Consequently, the number of distinct terms in $D^n(x_0)$ is the n -th Motzkin number M_n , that is,*

$$\Omega(D^n(x_0)) = M_n.$$

Proof. We proceed by induction on n .

Base Case: For $n = 1$, $D(x_0) = x_0 y_1$. The index set is $\mathcal{I} = \{1\}$ with $v_1 = y_1$. The sequence is $S = (L)$, which is the unique Motzkin path of length 1. Thus $M_1 = 1$.

Inductive Step: Assume the proposition holds for $n - 1$. Any term $w' \in D^n(x_0)$ is generated by applying the derivative operator D to some term $w \in D^{n-1}(x_0)$. By the definition of D , for a word $w = w_0 w_1 \dots w_k$:

$$D(w) = \sum_{j=0}^k \rho \left(w_0 \dots w_{j-1} R(w_j) \uparrow (w_{j+1} \dots w_k) \right).$$

Let $S = (s_1, \dots, s_{n-1})$ be the Motzkin path corresponding to w . We analyze the effect of R on each step:

Case 1: Derivation of x_0 ($j = 0$). Since $R(x_0) = x_0 y_1$, the new word starts with $x_0 y_1$ and all subsequent indices are shifted by 1. The new sequence becomes $S' = (L, s_1, s_2, \dots, s_{n-1})$. Since S is a Motzkin path, prefixing a Level step L results in a valid Motzkin path of length n .

Case 2: Derivation of x_m ($m \in \mathcal{I}, v_m = x_m$). The rule $R(x_m) = x_m y_{m+1}$ replaces x_m with $x_m y_{m+1}$ and shifts subsequent indices. In terms of steps, the original U step at position m remains U , and a new L step is inserted at $m + 1$. The sequence becomes $S' = (s_1, \dots, s_m, L, s_{m+1},$

\dots, s_{n-1}). Inserting L after an Up step preserves non-negativity and the final zero height.

Case 3: Derivation of y_m ($m \in \mathcal{I}, v_m = y_m$). The rule $R(y_m) = x_m$ replaces y_m with x_m and shifts subsequent indices. Note that the index $m+1$ is now "skipped" in the resulting word because no rule produced an index $m+1$. According to our characterization, a skipped index corresponds to a Down step D^* . Thus, the original L step at position m is replaced by the pair (U, D^*) . The sequence becomes $S' = (s_1, \dots, s_{m-1}, U, D^*, s_{m+1}, \dots, s_{n-1})$. Replacing L with (U, D^*) increases the intermediate height by 1 at one point and returns to the original height, thus preserving the Motzkin property.

Bijection: The mapping $\Phi : w \mapsto S$ is injective because S uniquely reconstructs the set \mathcal{I} and the variables v_i . To show surjectivity, any Motzkin path of length n can be reduced to a path of length $n - 1$ by reversing one of the three operations above (removing a leading L , removing an L that follows a U , or collapsing a (U, D^*) pair into an L). By the inductive hypothesis, all Motzkin paths of length n are covered. This completes the proof. \square

Proposition 6.10. *Let ϕ^{nc} denote the map sending $x_j \mapsto x$ and $y_j \mapsto y$, where x and y are non-commutative. Then the number of distinct terms in $\phi^{nc}(D^n(x_0))$ is the $(n + 1)$ -th Fibonacci number F_{n+1} , that is,*

$$\Omega(\phi^{nc}(D^n(x_0))) = F_{n+1}.$$

Proof. Let \mathcal{W}_n be the set of terms in $D^n(x_0)$. From the previous result, we know there is a bijection between \mathcal{W}_n and the set of Motzkin paths of length n . Let $P = (s_1, s_2, \dots, s_n)$ be a Motzkin path where $s_i \in \{U, L, D^*\}$ (U : Up-step, L : Level-step, D^* : Down-step).

Step 1. Structural Mapping: According to the characterization of terms, each step s_i in the Motzkin path corresponds to the variables in the word $w \in D^n(x_0)$ as follows:

- $s_i = U \iff$ the variable at index i is x_i .
- $s_i = L \iff$ the variable at index i is y_i .
- $s_i = D^* \iff$ index i is "skipped" (no variable exists with index i).

When we perform the mapping $x_j \rightarrow x$ and $y_j \rightarrow y$ and ignore indices, a term w is uniquely determined by the sequence of x 's and y 's it contains. Note that D^* steps (skipped indices) do not contribute a variable to the word. Thus, the word w (excluding x_0) is the sequence of x and y variables corresponding to the U and L steps in the path, in order.

Step 2. Combinatorial Counting: Let $k - 1$ be the number of U steps in a Motzkin path of length n . To be a valid Motzkin path ending at height 0, there must also be exactly $k - 1$ D^* steps. The remaining $n - 2(k - 1)$ steps must be L steps. The resulting word w after mapping will have:

- $k - 1$ instances of variable x .
- $n - 2k + 2$ instances of variable y .

The total number of variables in the word w is $(k-1)+(n-2k+2) = n-k+1$.

In the non-commutative case, the number of distinct words is the number of ways to arrange $k - 1$ x 's and $(n - k + 1) - (k - 1) = n - 2k + 2$ y 's such that the underlying Motzkin path is valid.

The number of ways to choose the positions of $k - 1$ units of x (each effectively "covering" two indices in the derivation history) out of a reduced sequence of $n - k + 1$ positions is given by the binomial coefficient:

$$\binom{n - k + 1}{k - 1}$$

Summing over all possible numbers of x variables (from $k - 1 = 0$ up to the maximum possible $\lfloor n/2 \rfloor$) to get

$$\Omega(\phi^{nc}(D^n(x_0))) = \sum_{k=1}^{\lfloor n/2 \rfloor + 1} \binom{n - k + 1}{k - 1}.$$

which equals F_{n+1} because

$$F_{n+1} = \sum_{m=0}^{\lfloor n/2 \rfloor} \binom{n - m}{m}.$$

This completes the proof. \square

Proposition 6.11. *Let ϕ denote the map sending $x_j \mapsto 1$, $y_j \mapsto 1$ and $q \mapsto 1$. Then $\phi(D^n(x_0)) = E_{n+1}$, the $(n + 1)$ -Euler numbers.*

Proof. This follows immediately from Theorem 6.5. \square

6.2. q -Grammar for q -André II polynomials.

Theorem 6.12. *Let G_{AndII} be the q -grammar defined by*

$$G_{\text{AndII}} = (\{x, y\}, \{x_j \rightarrow q^j x_j y_{j+1}, y_j \rightarrow q^{j+1} x_{j+1}\}, \mathbf{AIO}). \quad (6.21)$$

Let D be the q -derivative associated with G_{AndII} and define the evaluation map ϕ by $\phi(x_j) = x$ and $\phi(y_j) = y$. Then

$$\phi(D^n(x_0)) = E_{n+1}^{\text{II}}(q; x, y). \quad (6.22)$$

To prove Theorem 6.12, we first introduce the following statistic on André II trees.

For $T \in \mathcal{T}_n^{\text{II}}$ and $v \in T$, let L_v be the set of vertices on the path from the root 1 to v , say $L_v = \{v_0 := 1 < v_1 < \dots < v_{m-1} < v_m := v\}$. Let N_v denote the set of vertices in L_v whose right child is not contained in L_v . For

$v_i \in N_v$, let $T_{v_i}^r$ denote the subtree rooted at this right child and let $n_r(v_i)$ be the number of vertices in $T_{v_i}^r$ with convention that $n_r(v_i) = 0$ if $T_{v_i}^r = \emptyset$.

We define the following statistics for $v \in T$:

$$\Delta_{II}^T(v) = \sum_{v_i \in N_v} n_r(v_i) + |N_v|.$$

When the context of the tree T is clear, we simplify the notation to $\Delta_{II_3}(v)$.

For example, consider an André II tree T given in Fig. 8. By definition, we see that

$$\Delta_{II}^T(7) = 12.$$

Proposition 6.13. *Let T be an André II tree in \mathcal{T}_n^{II} and let u, v be two vertices in T each having at most one child. If u lies on or to the left of the path from the root 1 to v , then $\Delta_{II}(u) > \Delta_{II}(v)$; otherwise $\Delta_{II}(u) < \Delta_{II}(v)$.*

An insertion algorithm for André II trees: Let T be an André II tree on $[n]$. Suppose T has m vertices with at most one child. We present an insertion algorithm to generate m André II trees on $[n+1]$ by inserting $n+1$ into T .

If v is a leaf of T , then assign $n+1$ as the right child of v ; If v has one child of T , then assign $n+1$ as the left child of v . This yields an André II trees $\tilde{T} := \phi_v^{II}(T)$. It can be readily seen that the insertion algorithm is reversible.

From the construction of the insertion algorithm, it is not difficult to show that the following proposition.

Proposition 6.14. *Let T be an André II tree on $[n]$ and let v be a vertex in T with at most one child. Suppose that $\tilde{T} = \phi_v^{II}(T)$. Then*

$$\text{inv}(\tilde{T}) - \text{inv}(T) = \Delta_{II}^T(v). \tag{6.23}$$

Moreover, for any vertex u in T with at most one child,

(a) *If u lies on or to the left of the path from root 1 to v , then*

$$\Delta_{II}^{\tilde{T}}(u) = \Delta_{II}^T(u) + 1,$$

(b) *If u lies to the right of the path from root 1 to v , then*

$$\Delta_{II}^{\tilde{T}}(u) = \Delta_{II}^T(u),$$

(c) *If v is leaf, then*

$$\Delta_{II}^{\tilde{T}}(v) = \Delta_{II}^T(v) + 2.$$

(d) *If v has only one child, then*

$$\Delta_{II}^{\tilde{T}}(n+1) = \Delta_{II}^T(v).$$

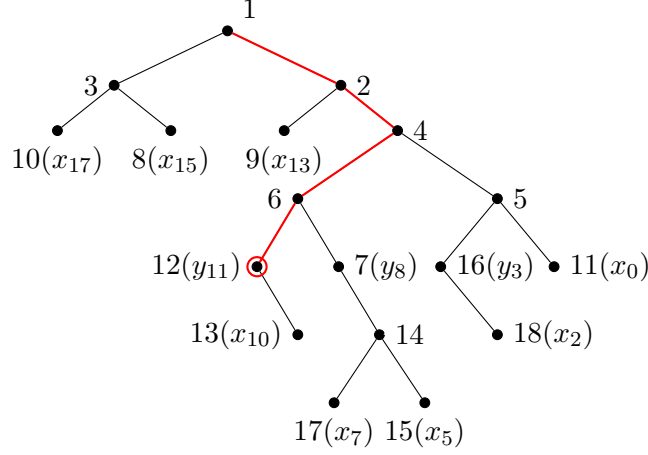
FIGURE 8. The labeling of an André II tree T on [18].

We are ready to prove Theorem 6.12 by using the grammatical labeling.

Let T be the André II trees on $[n]$. For $1 \leq i \leq n$, we label the vertex i in T as follows:

- If i is a leaf and $\Delta_H^T(i) = k$, then label it by x_k ;
- If i has only one child and $\Delta_H^T(i) = k$, then label it by y_{k-1} ;
- If i has two children, then it is left unlabeled.

Fig. 8 shows the grammatical labeling of the André II tree T .

The weight ω of T is defined to be the product of all labels of T arranged in **AIO** order. For the example above, we see that the weight of T is

$$\omega(T) = x_0 x_2 y_3 x_5 x_7 y_8 x_{10} y_{11} x_{13} x_{15} x_{17}.$$

To prove Theorem 6.12, we aim to show that the following assertion: For $n \geq 0$,

$$D^n(x_0) = \sum_{T \in \mathcal{T}_{n+1}^H} q^{\text{inv}(T)} \omega(T), \quad (6.24)$$

where D is q -derivative associated with q -grammar (6.21).

Proof of Theorem 6.12. We proceed by induction on n . For $n = 0$, the statement is evident. Assume that this statement holds for n , that is, the relation (6.24) is valid for $n - 1$. To demonstrate that it also holds for n , it suffices to show, by (6.24), that

$$D \left(\sum_{T \in \mathcal{T}_n^H} q^{\text{inv}(T)} \omega(T) \right) = \sum_{\tilde{T} \in \mathcal{T}_{n+1}^H} q^{\text{inv}(\tilde{T})} \omega(\tilde{T}). \quad (6.25)$$

Suppose T contains m vertices with at most one child and define the weight of T by

$$\omega(T) = \omega_1(T)\omega_2(T) \cdots \omega_m(T).$$

Applying the q -Leibnitz formula, we have

$$D(\omega(T)) = \sum_{i=1}^m \mathbf{AIO} \left(\omega_1(T) \cdots \omega_{i-1}(T) R(\omega_i(T)) \uparrow (\omega_{i+1}(T) \cdots \omega_m(T)) \right). \quad (6.26)$$

Let v_i be the vertex of T labeled by $\omega_i(T)$, and set $\tilde{T}^{(i)} = \phi_{v_i}^{\text{II}}(T)$. To establish (6.26), it is sufficient to show that

$$\begin{aligned} & q^{\text{inv}(T)} \mathbf{AIO} \left(\omega_1(T) \cdots \omega_{i-1}(T) R(\omega_i(T)) \uparrow (\omega_{i+1}(T) \cdots \omega_m(T)) \right) \\ &= q^{\text{inv}(\tilde{T}^{(i)})} \omega(\tilde{T}^{(i)}). \end{aligned} \quad (6.27)$$

Since the letters of $\omega(T)$ are arranged in **AIO** order, Proposition 6.6 implies that the vertices labeled $\omega_1(T), \dots, \omega_{i-1}(T)$ lie to the right of the path from 1 to v_i in T , while those labeled $\omega_{i+1}(T), \dots, \omega_m(T)$ lie either on this path or to its left. We consider two cases:

- Case 1: If $\omega_i(T) = x_k$, then v_i is a leaf of T with $\Delta_{\text{II}}^T(v_i) = k$. By Proposition 6.7, (6.27) holds since $D(x_k) = q^k x_k y_{k+1}$.
- Case 2: If $\omega_i(T) = y_k$, then v_i is a vertex of T with exactly one child and $\Delta_{\text{II}}^T(v_i) = k$. In light of Proposition 6.7, we find that (6.27) is satisfied since $D(y_k) = q^{k+1} x_{k+1}$.

Summing the results from these two cases shows that the assertion (6.25) holds, and thus (6.24) is valid for n . This completes the proof of Theorem 6.12. \square

We conclude this section with a grammatical derivation of the following identity for $E_{n+1}^{\text{II}}(q; x, y)$, which specializes to the relation for $E(x, y)$ established by Chen and Fu [6].

Theorem 6.15. *Set $E_0^{\text{II}}(q; x, y) = x$. For $n \geq 1$,*

$$\begin{aligned} & E_{n+1}^{\text{II}}(q; x, y) \\ &= y E_n^{\text{II}}(q; x, y) + \sum_{k=0}^{n-2} q^{2(n-k-1)} \begin{bmatrix} n-1 \\ k \end{bmatrix}_q E_{k+1}^{\text{II}}(q; x, y) E_{n-k-1}^{\text{II}}(q; x, y). \end{aligned} \quad (6.28)$$

Proof. Since the map ϕ from Theorem 6.12 is a master-linear evaluation, and the grammar G_{AndII} from (6.21) satisfies (4.4), Theorem 4.14 yields the multiplicative identity:

$$\phi(\text{Gen}^{(G_{\text{AndII}})}(x_0 y_1; u)) = \phi(\text{Gen}^{(G_{\text{AndII}})}(x_0; u)) \phi(\text{Gen}^{(G_{\text{AndII}})}(y_1; u)).$$

Consequently,

$$\phi(D^n(x_0y_1)) = \sum_{k=0}^n \begin{bmatrix} n \\ k \end{bmatrix}_q \phi(D^k(x_0))\phi(D^{n-k}(y_1)). \quad (6.29)$$

By Theorem 6.12, we have for all $k \geq 0$:

$$\phi(D^k(x_0)) = E_{k+1}^{\text{II}}(q; x, y). \quad (6.30)$$

Similarly, from the proof of Theorem 6.5, the order **AIO** in the grammar G_{AndII} is equivalent to the order **KSO**. It implies that the grammar G_{AndII} is q -linear. Hence, by Proposition 4.6, we derive that for all $k \geq 1$:

$$\phi(D^k(y_1)) = q^2\phi(D^{k-1}(x_2)) = q^2\phi(D^{k-1}(\uparrow^2 x_0)) = q^{2k}E_k^{\text{II}}(q; x, y). \quad (6.31)$$

Substituting (6.30) and (6.31) into (6.29) gives

$$\phi(D^n(x_0y_1)) = yE_{n+1}^{\text{II}}(q; x, y) + \sum_{k=0}^{n-1} q^{2(n-k)} \begin{bmatrix} n \\ k \end{bmatrix}_q E_{k+1}^{\text{II}}(q; x, y)E_{n-k}^{\text{II}}(q; x, y). \quad (6.32)$$

Meanwhile, Theorem 6.12 also implies that for $n \geq 1$,

$$\phi(D^n(x_0)) = \phi(D^{n-1}(x_0y_1)) = E_{n+1}^{\text{II}}(q; x, y). \quad (6.33)$$

The recurrence (6.28) follows from (6.32) and (6.33). \square

APPENDIX I. OVERVIEW OF CONTEXT-FREE GRAMMAR IN COMBINATORICS

Given a finite or infinite alphabet $X = \{x_1, x_2, x_3, \dots\}$ and the commutative algebra $\mathbb{K}[[X]]$ of formal power series in the variables x_i , a *context-free grammar* is a collection of substitution rules that replace each variable in X by a formal function or a formal power series over X . This notion was introduced by Chen [5]. Equivalently, a context-free grammar is an application

$$G: X \longrightarrow \mathbb{K}[[X]],$$

which can be written in the form

$$G = \{x_1 \rightarrow G(x_1), x_2 \rightarrow G(x_2), x_3 \rightarrow G(x_3), \dots\},$$

where each $G(x_i)$ is a formal function or a formal power series over X . As pointed out by Chen [5], these substitution rules resemble context-free grammars in formal language theory, which motivates the terminology. Dumont [19] later referred to such grammars as *William Chen's grammars*.

To a grammar G , one associates a *formal derivation* D_G , or simply D , which coincides with G on X and treats each substitution rule as a differential rule. More precisely, for a variable $x_i \in X$, if there is a production $x_i \rightarrow G(x_i)$ in the grammar G , then we define $D(x_i) = G(x_i)$; otherwise, we set $D(x_i) = 0$, and such a variable is called a *constant* or a *terminal*. For

two formal functions f and g in $\mathbb{K}[[X]]$, the formal derivation D satisfies the following relations:

$$D(f + g) = D(f) + D(g), \tag{I.1}$$

$$D(fg) = D(f)g + fD(g). \tag{I.2}$$

It follows that Leibniz's rule remains valid for the formal derivative D :

$$D^n(fg) = \sum_{k=0}^n \binom{n}{k} D^k(f) D^{n-k}(g). \tag{I.3}$$

In [5], Chen developed a systematic *grammar calculus*. To this end, Chen associated the derivation D induced by a grammar G with an exponential generating function. For a formal function f in $\mathbb{K}[[X]]$, define

$$\text{Gen}^{(G)}(f; u) = \sum_{n \geq 0} D_G^n(f) \frac{u^n}{n!}. \tag{I.4}$$

This construction provides grammatical interpretations of addition, multiplication, and functional composition of formal functions. More precisely, by (I.1) and (I.2), one readily obtains

$$\text{Gen}^{(G)}(f + g; u) = \text{Gen}^{(G)}(f; u) + \text{Gen}^{(G)}(g; u), \tag{I.5}$$

$$\text{Gen}^{(G)}(fg; u) = \text{Gen}^{(G)}(f; u) \text{Gen}^{(G)}(g; u), \tag{I.6}$$

$$\text{Gen}(D(f); u) = \frac{d}{du} \text{Gen}(f; u), \tag{I.7}$$

$$\int \text{Gen}(f; u) du = \text{Gen}\left(\int f dG; u\right), \tag{I.8}$$

where if $g = \int f dG$, then $D(g) = f$.

Using this framework, Chen [5] obtained elegant proofs of Faà di Bruno's formula and various identities involving Bell polynomials, Stirling numbers, and symmetric functions. In particular, the Lagrange inversion formula admits a concise grammatical interpretation, from which Cayley's formula for labeled trees emerges naturally.

A context-free grammar exhibits two complementary aspects: a combinatorial aspect and a computational aspect. Given a grammar G and its associated derivation D , one studies the sequence of formal functions:

$$f, D(f), D^2(f), \dots, D^n(f), \dots$$

On the combinatorial side, the goal is to interpret $D^n(f)$ as enumerating certain combinatorial objects associated with some statistics. On the computational side, the same grammar governs algebraic manipulations of formal functions, which constitutes the essence of grammar calculus.

As an illustrative example, consider the grammar

$$G = \{x \rightarrow xy, y \rightarrow xy\}. \quad (\text{I.9})$$

This grammar is closely related to Eulerian polynomials that record the number of descents of permutations, and it was formally introduced by Dumont [19].

The associated derivation D is given by

$$D(x) = xy, \quad D(y) = xy.$$

Straightforward calculations yield

$$D^2(x) = xy^2 + x^2y,$$

and further

$$D^3(x) = xy^3 + 4x^2y^2 + x^3y.$$

Let \mathfrak{S}_n denote the set of permutations on $[n]$. For $n \geq 1$, the bivariate Eulerian polynomials are defined by

$$A_n(x, y) = \sum_{\sigma \in \mathfrak{S}_n} x^{\text{asc}(\sigma)} y^{\text{des}(\sigma)},$$

where $\text{des}(\sigma)$ and $\text{asc}(\sigma)$ denote the numbers of descents and ascents of σ , respectively, with the convention that σ is padded by zeros at both ends, see the beginning of Section 5 for their definitions. Dumont [19] showed that for $n \geq 1$,

$$A_n(x, y) = D^n(x), \quad (\text{I.10})$$

with $A_0(x, y) = x$.

Chen and Fu [6] introduced the notion of a *grammatical labeling* for (I.10), which exhibits how the substitution rules in context-free grammar arise in the construction of the combinatorial structures. This idea was already implicit in Chen's original work on partitions [5]. Grammatical labelings thus serve as a bridge between combinatorial structures and grammars.

The exponential generating function of Eulerian polynomials is well known:

$$\text{Gen}(x; u) = \sum_{n=0}^{\infty} A_n(x, y) \frac{u^n}{n!} = \frac{x - y}{1 - x^{-1}y e^{(x-y)u}}. \quad (\text{I.11})$$

The grammar calculus provides a transparent derivation of (I.11). Since $D(x) = D(y) = xy$, we obtain

$$D(x^{-1}) = -x^{-1}y, \quad D(x^{-1}y) = (x - y)x^{-1}y.$$

Notably, $x - y$ behaves as a constant associated with D , since $D(x - y) = 0$. This observation leads to

$$D^n(x^{-1}y) = (x - y)^n x^{-1}y,$$

and consequently to the generating function of x^{-1} . Using the identity

$$\text{Gen}(x; u)\text{Gen}(x^{-1}; u) = 1,$$

one immediately recovers (I.11).

Dumont was a strong advocate of grammatical methods, discovering grammars for numerous combinatorial families: Roselle polynomials (on permutations), second-order Eulerian polynomials (on Stirling permutations), 0-1-2 increasing trees (André trees), increasing binary/plane trees, Ramanujan-Shor polynomials (on rooted trees), and Schett polynomials (related to Jacobi elliptic functions), see for example, [17, 18, 19, 20].

Dumont [19] termed the following polynomials defined on permutations as Roselle polynomials:

$$F_n(x, y, z) = \sum_{\sigma \in \mathfrak{S}_n} x^{\text{exc}(\sigma)} y^{\text{drop}(\sigma)} z^{\text{fix}(\sigma)},$$

where $\text{exc}(\sigma)$, $\text{drop}(\sigma)$ and $\text{fix}(\sigma)$ denote the number of excedances, the number of drops and the number of fixed points of σ , respectively. For the definitions of excedances, drops and fixed points, please refer to the beginning of Section 5.

Dumont [19] showed that the polynomials $F_n(x, y, z)$ can be generated by the following grammar

$$G = \{a \rightarrow az, z \rightarrow xy, x \rightarrow xy, y \rightarrow xy\}. \quad (\text{I.12})$$

Let D be the formal derivative associated with (I.12), Dumont showed that

$$D^n(a) = aF_n(x, y, z). \quad (\text{I.13})$$

A grammatical labeling for (I.13) was given by Chen and Fu [8], who also derived the generating function of Roselle polynomials via grammatical methods.

Let \mathcal{T}_n be the set of 0-1-2 increasing trees on $\{0, 1, \dots, n-1\}$. The André polynomial $E_n(x, y)$ is defined by

$$E_n(x, y) = \sum_{T \in \mathcal{T}_n} x^{l(T)} y^{u(T)},$$

where $l(T)$ and $u(T)$ denote the number of leaves of T and the number of vertices of T with degree 1, respectively. For further details, we refer to Section 6.

Dumont [19] introduced the formal grammar

$$G = \{x \rightarrow xy, y \rightarrow x\}. \quad (\text{I.14})$$

Let D be the formal derivative associated with (I.14), Dumont [19] showed that

$$D^n(y) = E_n(x, y). \quad (\text{I.15})$$

Chen and Fu [6] provided a grammatical labeling for (I.15) and deduced the generating function formula for André polynomials using grammatical calculus. This formula was first obtained by Foata and Schützenberger [26]

via a differential equation. Notably, Foata and Han [23] developed a method to compute the generating function of $E(x, 1)$ without solving a differential equation.

In recent years, grammatical approaches to variations and generalizations of Eulerian polynomials have been extensively studied; see, for example, [7, 8, 9, 10, 12, 13, 29, 30, 35, 39, 40, 44, 45, 47, 48].

Grammatical calculus for tree-enumerative polynomials originated with Dumont and Ramamonjisoa [20]. They established a grammar for Ramanujan–Shor polynomials, which arise from the enumeration of rooted trees counted by improper edges and provide a refinement of Cayley’s formula for rooted trees on n vertices; see [55, 62]. Subsequent grammatical labelings and recursive grammars recover classic functional equations satisfied by Ramanujan–Shor polynomials, as developed in [11, 14]. Parallel advances concern Narayana and Motzkin polynomials arising from plane tree statistics, along with their stable multivariate generalizations [16, 61].

Beyond generating functions, grammars have also proved effective in establishing γ -positivity of combinatorial polynomials, constructing bijections, and establishing the stability of multivariate combinatorial polynomials.

Ma, Ma, and Yeh [47] made the observation that a transformation of Dumont’s grammar (I.9) yields the γ -positivity of Eulerian polynomials. Chen and Fu [7] further showed that the transformed grammar not only implies γ -positivity but also provides a combinatorial interpretation of the γ -coefficients in terms of increasing plane trees. Subsequently, grammatical transformations have been successfully applied to establish the γ -positivity (e-positivity) of various modifications and generalizations of Eulerian polynomials and Ramanujan polynomials; see Chen, Fu, and Yan [12], Ji [39], Ji and Lin [40], Dong et al. [16].

Grammar also facilitates the construction of combinatorial bijections. If two combinatorial structures admit the same grammar, then grammar can be leveraged to assist in establishing explicit bijections between them, see Chen and Fu [9, 10] and Chen, Fu and Wang [11] for example.

Grammars for the descent polynomials of Legendre–Stirling permutations and marked Stirling permutations were constructed by Chen, Hao, and Yang [13], yielding stable multivariate generalizations, where stability is equivalent to real-rootedness in the univariate case.

Overall, grammatical methods allow one to derive generating functions and identities without explicit reliance on recurrence relations or differential equations. Beyond enumeration, grammatical approaches have also been applied to construct bijections, to establish γ -positivity of combinatorial polynomials, and to prove the stability of multivariate combinatorial polynomials.

APPENDIX II. FORMULAS FOR q -DERIVATIVES AND THEIR
 q -EXPONENTIAL GENERATING FUNCTIONS

Proposition II.1. *Let D be the q -derivative associated with a q -grammar. For $f, g \in \mathbb{E}$ and $c \in \mathbb{K}[q]$, we have*

$$D(c) = 0, \quad (\text{II.1})$$

$$D(cf) = cD(f), \quad (\text{II.2})$$

$$D(f + g) = D(f) + D(g), \quad (\text{II.3})$$

$$D(f^{-1}) = -f^{-1}D(f) \uparrow (f^{-1}). \quad (\text{II.4})$$

Proposition II.2. *Let D be the q -derivative associated with a q -linear grammar. For $f, g \in \mathbb{E}$, we have*

$$D(fg) = D(f) \uparrow g + fD(g), \quad (\text{II.5})$$

$$D^n(\uparrow^m f) = q^{nm} \uparrow^m (D^n(f)), \quad (\text{II.6})$$

$$D^n(fg) = \sum_{k=0}^n \begin{bmatrix} n \\ k \end{bmatrix}_q D_q^k(f) \uparrow^k (D_q^{(n-k)}(g)). \quad (\text{II.7})$$

Let D be the q -derivative associated with a q -grammar G . For $f \in \mathbb{E}$, the q -exponential generating function of $D^n(f)$ is defined by

$$\text{Gen}_q^{(G)}(f; u) = \sum_{n \geq 0} D^n(f) \frac{u^n}{(q; q)_n}.$$

Proposition II.3. *We have*

$$\text{Gen}_q^{(G)}(f + g; u) = \text{Gen}_q^{(G)}(f; u) + \text{Gen}_q^{(G)}(g; u), \quad (\text{II.8})$$

$$D_q \text{Gen}_q^{(G)}(f; u) = \text{Gen}_q^{(G)}(D(f); u), \quad (\text{II.9})$$

where D_q is a real q -derivative defined in (2.1).

Proposition II.4. *Let G be a q -linear grammar and let D be the q -derivative associated with G , then for $f, g \in \mathbb{E}$,*

$$\text{Gen}_q^{(G)}(fg; u) = \sum_{k \geq 0} D^k(f) \frac{u^k}{(q; q)_k} \uparrow^k \text{Gen}_q^{(G)}(g; u), \quad (\text{II.10})$$

$$\text{Gen}(\uparrow^m f; u) = \uparrow^m \text{Gen}(f; uq^m). \quad (\text{II.11})$$

If ϕ is a master-linear evaluation, then

$$\phi \left(\text{Gen}_q^{(G)}(fg; u) \right) = \phi \left(\text{Gen}_q^{(G)}(f; u) \right) \cdot \phi \left(\text{Gen}_q^{(G)}(g; u) \right). \quad (\text{II.12})$$

Theorem II.5. *Let $G = (S, R, \rho)$ be a q -grammar, where for each variable $s_i \in \mathbb{S}$ and any $i \geq 0$, we have $R(s_{i+1}) = R(\uparrow s_i) = q \uparrow R(s_i)$. Let ϕ be a*

master-linear evaluation, that is, for any two variables $s_i, s_j \in \mathbb{S}$, $\phi(s_i) = \phi(s_j)$. We have

$$\phi\left(\text{Gen}_q^{(G)}(fg; u)\right) = \phi\left(\text{Gen}_q^{(G)}(f; u)\right) \cdot \phi\left(\text{Gen}_q^{(G)}(g; u)\right). \quad (\text{II.13})$$

APPENDIX III. NUMBERS OF TERMS OF THE q -GRAMMARS

For the q -grammar G_{tan} , the initial values of the numbers of terms $\Omega(D^n(x_0))$ are (2, 3, 9, 20, 38, 65, 101, 150, 210, 287, 377, ...). The exact formula is (see Lemma 3.9)

$$\Omega(D^n(x_0)) = \begin{cases} 2k^3 + 5k^2 + 2, & \text{if } n = 2k + 1, \\ (k + 2)(2k^2 - 2k + 1), & \text{if } n = 2k. \end{cases}$$

For the q -grammar $G_{\text{tan}'}$, the initial values of the numbers of terms $\Omega(D^n(x_0))$ are (2, 3, 5, 8, 13, 21, 34, 55, 89, 144, 233, ...). The exact formula is $\Omega(D^n(x_0)) = F_{n+2}$, where F_n is the n -th Fibonacci number.

For the q -grammar G_{sec} , the initial values of the numbers of terms $\Omega(D^n(y_0))$ are (1, 3, 8, 19, 36, 63, 98, 147, 206, 283, 372, ...). The exact formula is

$$\Omega(D^n(y_0)) = \begin{cases} 1, & \text{if } n = 1, \\ 2k^3 + 5k^2 - k + 2, & \text{if } n = 2k + 1, \quad (k \geq 1) \\ 2k^3 + 2k^2 - 4k + 3, & \text{if } n = 2k. \quad (k \geq 1) \end{cases}$$

For the q -grammar $G_{\text{sec}'}$, the initial values of the numbers of terms $\Omega(D^n(y_0))$ are (1, 2, 3, 5, 8, 13, 21, 34, 55, 89, 144, ...). The exact formula is $\Omega(D^n(y_0)) = F_{n+1}$.

For the q -grammar G_{Sec} , the initial values of the numbers of terms $\Omega(D^n(y_0))$ are (1, 3, 8, 23, 48, 86, 139, 210, 301, 415, 554, ...). The exact formula is

$$\Omega(D^n(y_0)) = \begin{cases} 1, & \text{if } n = 1, \\ 3, & \text{if } n = 2, \\ \frac{1}{6}(20k^3 + 33k^2 + k - 6), & \text{if } n = 2k + 1, \quad (k \geq 1) \\ \frac{1}{6}(20k - 17)(k + 1)k, & \text{if } n = 2k. \quad (k \geq 2) \end{cases}$$

For the q -grammar $G_{\text{Sec}'}$, the initial values of the numbers of terms $\Omega(D^n(y_0))$ are (1, 3, 8, 21, 53, 132, 325, 795, 1936, 4701, 11393, ...). An explicit closed-form expression for this sequence has not been obtained.

For the q -grammar G_{maj} , the initial values of the numbers of terms $\Omega(D^n(x_0))$ are (1, 2, 6, 20, 73, 283, 1147, 4814, 20774, ...). An explicit closed-form expression for this sequence has not been obtained.

For the q -grammar G_{inv} , the initial values of the numbers of terms $\Omega(D^n(x_0))$ are $(1, 2, 4, 8, 16, 32, 64, 128, 256, 512, \dots)$. The exact formula is $\Omega(D^n(x_0)) = 2^{n-1}$.

For the q -grammar G_{cyc} , the initial values of the numbers of terms $\Omega(D^n(e_0))$ are $(1, 2, 5, 12, 28, 65, 151, 351, 816, 1897, \dots)$. The exact formula is

$$\Omega(D^n(e_0)) = \sum_{k=0}^{\lfloor (n+1)/2 \rfloor} \binom{n+k}{3k}.$$

For the q -grammar G_{And^I} , the initial values of the numbers of terms $\Omega(D^n(x_0))$ are $(1, 2, 4, 9, 21, 51, 127, 323, 835, 2188, 5798, \dots)$. The exact formula is $\Omega(D^n(x_0)) = M_n$, where M_n is the n -th Motzkin number (Proposition 6.9).

For the q -grammar G_{And^II} , the initial values of the numbers of terms $\Omega(D^n(x_0))$ are $(1, 2, 3, 5, 8, 13, 21, 34, 55, 89, 144, \dots)$. The exact formula is $\Omega(D^n(x_0)) = F_{n+1}$.

Acknowledgment. This work was initiated during the 2025 Workshop on Enumerative Combinatorics at Shandong University, Qingdao Campus. The authors would like to thank Zhicong Lin, the workshop organizer, for providing a valuable platform for academic exchange. This work was supported by the National Natural Science Foundation of China.

REFERENCES

- [1] Martin Aigner. *Combinatorial Theory*, volume 234 of *Grundlehren der Mathematischen Wissenschaften*. Springer-Verlag, New York, Berlin, Heidelberg, 1979. 19
- [2] George E. Andrews. *The theory of partitions*, volume Vol. 2 of *Encyclopedia of Mathematics and its Applications*. Addison-Wesley Publishing Co., Reading, Mass.-London-Amsterdam, 1976. 18
- [3] Leonard Carlitz. q -Bernoulli and Eulerian numbers. *Transactions of the American Mathematical Society*, 76:332–350, 1954. 26
- [4] Leonard Carlitz. A combinatorial property of q -Eulerian numbers. *The American Mathematical Monthly*, 82(1):51–54, 1975. 26
- [5] William Y. C. Chen. Context-free grammars, differential operators and formal power series. *Theoret. Comput. Sci.*, 117 (1-2):113–129, 1993. 1, 2, 5, 15, 56, 57, 58
- [6] William Y. C. Chen and Amy M. Fu. Context-free grammars for permutations and increasing trees. *Adv. in Appl. Math.*, 82:58–82, 2017. 25, 28, 40, 48, 55, 58, 59
- [7] William Y. C. Chen and Amy M. Fu. A context-free grammar for the e -positivity of the trivariate second-order Eulerian polynomials. *Discrete Math.*, 345(1):Paper No. 112661, 9, 2022. 60
- [8] William Y. C. Chen and Amy M. Fu. The Dumont ansatz for the Eulerian polynomials, peak polynomials and derivative polynomials. *Ann. Comb.*, 27(3):707–735, 2023. 26, 59, 60
- [9] William Y. C. Chen and Amy M. Fu. A grammatical calculus for peaks and runs of permutations. *J. Algebraic Combin.*, 57(4):1139–1162, 2023. 60
- [10] William Y. C. Chen and Amy M. Fu. A grammar of Dumont and a theorem of Diaconis-Evans-Graham. *Adv. in Appl. Math.*, 160:Paper No. 102743, 18, 2024. 60

- [11] William Y. C. Chen, Amy M. Fu, and Elena L. Wang. A grammatical calculus for the ramanujan polynomials, 2025. [60](#)
- [12] William Y. C. Chen, Amy M. Fu, and Sherry H. F. Yan. The Gessel correspondence and the partial γ -positivity of the Eulerian polynomials on multiset Stirling permutations. *European J. Combin.*, 109:Paper No. 103655, 13, 2023. [60](#)
- [13] William Y. C. Chen, Robert X. J. Hao, and Harold R. L. Yang. Context-free grammars and stable multivariate polynomials over Stirling permutations. In *Algorithmic combinatorics: enumerative combinatorics, special functions and computer algebra—in honour of Peter Paule on his 60th birthday*, Texts Monogr. Symbol. Comput., pages 109–135. Springer, Cham, [2020] ©2020. [60](#)
- [14] William Y. C. Chen and Harold R. L. Yang. A context-free grammar for the Ramanujan-Shor polynomials. *Adv. in Appl. Math.*, 126:Paper No. 101908, 24, 2021. [60](#)
- [15] Noam Chomsky. Three models for the description of language. *IRE Transactions on information theory*, 2(3):113–124, 1956. [2](#), [5](#)
- [16] Janet J. W. Dong, Lora R. Du, Kathy Q. Ji, and Dax T. X. Zhang. New refinements of Narayana polynomials and Motzkin polynomials. *Adv. in Appl. Math.*, 166:Paper No. 102855, 40, 2025. [60](#)
- [17] Dominique Dumont. Une généralisation trivariée symétrique des nombres eulériens. *J. Combin. Theory Ser. A*, 28(3):307–320, 1980. [59](#)
- [18] Dominique Dumont. Une approche combinatoire des fonctions elliptiques de jacobi. *Adv. in Math.*, 41:1–39, 1981. [59](#)
- [19] Dominique Dumont. Grammaires de William Chen et dérivations dans les arbres et arborescences. *Sém. Lothar. Combin.*, 37:Art. B37a, 21, 1996. [1](#), [25](#), [26](#), [39](#), [40](#), [56](#), [58](#), [59](#)
- [20] Dominique Dumont and Armand Ramamonjisoa. Grammaire de Ramanujan et arbres de Cayley. *Electron. J. Combin.*, 3(2):Research Paper 17, approx. 18, 1996. The Foata Festschrift. [59](#), [60](#)
- [21] Leonhard Euler. De partitione numerorum. In Adolf Krazer and Ferdinand Rudio, editors, *Introductio in analysin infinitorum*, volume 18 of *Opera Omnia*, chapter 16, pages 313–338. B.G. Teubner, 1748. Reprinted in 1922. [3](#)
- [22] Dominique Foata and Guo-Niu Han. Arbres minimax et polynômes d’andré. *Advances in Applied Mathematics*, 27(2-3):367–389, 2001. [42](#)
- [23] Dominique Foata and Guo-Niu Han. Arbres minmax et polynômes d’andré. *Advances in Applied Mathematics*, 27(2-3):367–389, 2001. [59](#)
- [24] Dominique Foata and Guo-Niu Han. Multivariable tangent and secant q -derivative polynomials. *Mosc. J. Comb. Number Theory*, 2(3):34–84, 2012. [1](#), [2](#), [3](#), [4](#), [12](#), [13](#), [14](#)
- [25] Dominique Foata and Marcel-P. Schützenberger. *Théorie géométrique des polynômes eulériens*, volume Vol. 138 of *Lecture Notes in Mathematics*. Springer-Verlag, Berlin-New York, 1970. [26](#), [27](#)
- [26] Dominique Foata and Marcel-Paul Schützenberger. Nombres d’euler et permutations alternantes. In J. N. et al. Srivastava, editor, *A survey of combinatorial theory*, pages 173–187. North-Holland, Amsterdam, 1973. [40](#), [59](#)
- [27] Dominique Foata and Volker Strehl. Rearrangements of the symmetric group and enumerative properties of the tangent and secant numbers. *Mathematische Zeitschrift*, 137(3):257–264, 1974. [40](#)
- [28] Dominique Foata and Volker Strehl. Euler numbers and variations of permutations, colloquio. *Internazionale sulle Teorie Combinatorie (Roma, 1973)*, Tomo I, 119–131. *Atti dei Convegni Lincei, No. 17, Accademia Nazionale dei Lincei, Rome*, 1976. [40](#)
- [29] Amy M. Fu. A context-free grammar for peaks and double descents of permutations. *Adv. in Appl. Math.*, 100:179–196, 2018. [60](#)
- [30] Amy M. Fu and Frank Z. K. Li. Joint distributions of permutation statistics and the parabolic cylinder functions. *European J. Combin.*, 85:103060, 23, 2020. [60](#)

- [31] Adriano M. Garsia. On the ‘maj’ and ‘inv’ q -analogues of Eulerian polynomials. *Linear and Multilinear Algebra*, 8(1):21–34, 1979/80. [26](#)
- [32] George Gasper and Mizan Rahman. *Basic hypergeometric series*, volume 96 of *Encyclopedia of Mathematics and its Applications*. Cambridge University Press, Cambridge, second edition, 2004. With a foreword by Richard Askey. [2](#), [3](#)
- [33] Ira M. Gessel, Bruce E. Sagan, and Yeong-Nan Yeh. Enumeration of trees by inversions. *Journal of Graph Theory*, 19(4):435–459, 1995. [42](#)
- [34] Jay Goldman and Gian-Carlo Rota. On the foundations of combinatorial theory iv: Finite vector spaces and eulerian generating functions. *Studies in Applied Mathematics*, 49(3):239–258, 1970. [15](#)
- [35] Guo-Niu Han and Shi-Mei Ma. Eulerian polynomials and the g -indices of Young tableaux. *Proc. Amer. Math. Soc.*, 152(4):1437–1449, 2024. [60](#)
- [36] Michael E. Hoffman. Derivative polynomials for tangent and secant. *Amer. Math. Monthly*, 102(1):23–30, 1995. [13](#)
- [37] John E Hopcroft, Jeffrey D Ullman, Rajeev Motwani, et al. Introduction to automata theory, languages, and computation, 2001. [2](#), [5](#)
- [38] F. H. Jackson. A basic-sine and cosine with symbolical solutions of certain differential equations. *Proc. Edinburgh Math. Soc.*, 22:28–39, 1904. [3](#)
- [39] Kathy Q. Ji. The (α, β) -Eulerian polynomials and descent-Stirling statistics on permutations. *Sci. China Math.*, 68(9):2259–2284, 2025. [60](#)
- [40] Kathy Q. Ji and Zhicong Lin. The binomial-Stirling-Eulerian polynomials. *European J. Combin.*, 120:Paper No. 103962, 15, 2024. [60](#)
- [41] David Lawrence Johnson. *Topics in the theory of group presentations*, volume 42. Cambridge University Press, 1980. [5](#)
- [42] Gérald Ksavrelof and Jiang Zeng. Two involutions for signed excedance numbers. *Séminaire Lotharingien de Combinatoire*, 49:Article B49e, 8 pages, 2003. Available at <https://www.mat.univie.ac.at/~slc/wpapers/s49zeng.pdf>. [26](#)
- [43] A. G. Kuznetsov, I. M. Pak, and A. E. Postnikov. Increasing trees and alternating permutations. *Russian Mathematical Surveys*, 49(6):79–114, 1994. [40](#)
- [44] Shi-Mei Ma. Derivative polynomials and enumeration of permutations by number of interior and left peaks. *Discrete Math.*, 312(2):405–412, 2012. [60](#)
- [45] Shi-Mei Ma, Qi Fang, Toufik Mansour, and Yeong-Nan Yeh. Alternating Eulerian polynomials and left peak polynomials. *Discrete Math.*, 345(3):Paper No. 112714, 12, 2022. [60](#)
- [46] Shi-Mei Ma, Jun Ma, Jean Yeh, and Yeong-Nan Yeh. Excedance-type polynomials, gamma-positivity and alternatingly increasing property. *European Journal of Combinatorics*, 118:103869, 2024. [26](#)
- [47] Shi-Mei Ma, Jun Ma, and Yeong-Nan Yeh. γ -positivity and partial γ -positivity of descent-type polynomials. *J. Combin. Theory Ser. A*, 167:257–293, 2019. [60](#)
- [48] Shi-Mei Ma, Jun Ma, Yeong-Nan Yeh, and Bao-Xuan Zhu. Context-free grammars for several polynomials associated with Eulerian polynomials. *Electron. J. Combin.*, 25(1):Paper No. 1.31, 17, 2018. [60](#)
- [49] C. L. Mallows and John Riordan. The inversion enumerator for labeled trees. *Bull. Amer. Math. Soc.*, 74(1):92–96, 1968. [42](#)
- [50] T. Kyle Petersen. *Eulerian Numbers*. Birkhäuser Advanced Texts: Basler Lehrbücher. Birkhäuser/Springer, New York, 2015. [26](#)
- [51] Jean-Pierre Serre et al. *Linear representations of finite groups*, volume 42. Springer, 1977. [5](#)
- [52] John Shareshian and Michelle L. Wachs. q -Eulerian polynomials: excedance number and major index. *Electronic Research Announcements of the American Mathematical Society*, 13:33–45, 2007. [26](#)
- [53] John Shareshian and Michelle L. Wachs. Eulerian quasisymmetric functions. *Advances in Mathematics*, 225(6):2921–2966, 2011. [26](#)

- [54] Heesung Shin and Jiang Zeng. The symmetric and unimodal expansion of Eulerian polynomials via continued fractions. *European J. Combin.*, 33(2):111–127, 2012. [26](#)
- [55] Peter W. Shor. A new proof of Cayley’s formula for counting labeled trees. *J. Combin. Theory Ser. A*, 71(1):154–158, 1995. [60](#)
- [56] Michael Sipser. Introduction to the theory of computation, 2012. [2](#), [5](#)
- [57] Richard P. Stanley. Binomial posets, Möbius inversion, and permutation enumeration. *J. Combinatorial Theory Ser. A*, 20(3):336–356, 1976. [28](#)
- [58] Richard P. Stanley. A survey of alternating permutations. In *Combinatorics and Graphs: The Twentieth Anniversary Conference of IPM Combinatorics*, volume 531 of *Contemporary Mathematics*, pages 165–196. American Mathematical Society, 2010. [40](#)
- [59] Richard P. Stanley. *Enumerative combinatorics. Volume 1*, volume 49 of *Cambridge Studies in Advanced Mathematics*. Cambridge University Press, Cambridge, second edition, 2012. [41](#)
- [60] Volker Strehl. Nombres d’euler et permutations alternantes. *Ph. D. Thesis, University of Florida, Gainesville*, 1974. [40](#)
- [61] Harold R. L. Yang and Philip B. Zhang. Stable multivariate Narayana polynomials and labeled plane trees. *Adv. in Appl. Math.*, 166:Paper No. 102867, 23, 2025. [60](#)
- [62] Jiang Zeng. A Ramanujan sequence that refines the Cayley formula for trees. *Ramanujan J.*, 3(1):45–54, 1999. [60](#)

I.R.M.A., UMR 7501, UNIVERSITÉ DE STRASBOURG ET CNRS, 7 RUE RENÉ DESCARTES,
F-67084 STRASBOURG, FRANCE

Email address: guoniu.han@unistra.fr

CENTER FOR APPLIED MATHEMATICS AND KL-AAGDM, TIANJIN UNIVERSITY, TIANJIN 300072, P.R. CHINA

Email address: kathyji@tju.edu.cn

INSTITUTE FOR ADVANCED STUDY IN MATHEMATICS, HARBIN INSTITUTE OF TECHNOLOGY, HEILONGJIANG 150001, P.R. CHINA

Email address: huan.xiong.math@gmail.com